

PART 5 - OPTIONS

CONTENTS

Para		Page
5.1	SYSTEM EXPANSION	5-5
5.2	SENSORS	5-5
5.2.1	Heel Angle Sensor	5-5
5.2.2	Mast Rotation Sensor	5-5
5.2.3	Trim Angle Sensor	5-5
5.2.4	Barometric Pressure Sensor	5-5
5.2.5	Rudder Angle Sensor	5-6
5.2.6	Sea Temperature Sensor	5-6
5.2.7	Air Temperature Sensor	5-6
5.2.8	Load Cells	5-6
5.2.9	Sensor Input Configuration	5-6
5.3	DISPLAYS	5-7
5.3.1	Halcyon Display	5-7
5.3.2	Options Available	5-8
5.3.3	Analogue Indicators	5-9
5.3.4	Analogue Indicator Configuration	5-9
5.3.5	Meter Scaling	5-10
5.4	20/20 CD DISPLAY	5-11
5.4.1	The Display	5-11
5.4.2	Display Configuration	5-11
5.4.3	Function Selection - Remote Pushbutton	5-12
5.4.4	Function Selection - FFD	5-12
5.4.5	Re-configuring 20/20 CD	5-13
5.5	40/40 CD DISPLAY	5-14
5.5.1	The Display	5-14
5.5.2	Display Configuration	5-14
5.5.3	Function Selection - Remote Pushbutton	5-15
5.5.4	Function Selection - FFD	5-15
5.5.5	Re-configuring 40/40 CD	5-16
5.6	GRAVITY SWITCH	5-17
5.7	AUDIBLE ALARM	5-17

CONTENTS (Contd.)

Para		Page
5.8	NMEA INTERFACE	5-17
5.8.1	Displaying NMEA Functions	5-18
5.8.2	Selection of Equipment	5-18
5.8.3	NMEA Input and Output Configuration	5-22
5.8.4	Changing NMEA/RS232 Configuration	5-23
5.8.5	Fast HDM Option	5-23
5.8.6	True/Magnetic Reference Selection	5-24
5.8.7	Handling of Alarm Conditions	5-25
5.8.8	NMEA-based Data on the B&G Network	5-25
5.8.9	NMEA 0183 Sentences	5-25
5.9.	RS232 INTERFACING	5-42
5.9.1	RS232C Input and Output Configuration	5-42
5.9.2	Changing NMEA/RS232 Configuration	5-42
5.9.3	Command Syntax	5-44
5.9.4	Channel Numbers	5-44
5.9.5	Automatic Output Enable/Disable	5-47
5.9.6	Automatic Output Start/Stop	5-47
5.9.7	Input Remote Channel Data and Text	5-48
5.9.8	Automatic Output of Basic Data	5-48
5.9.9	Immediate Output of Basic Data	5-49
5.9.10	Immediate Output of Channel or Remote Data	5-49
5.9.11	Output Latitude and Longitude	5-50
5.9.12	Assign Remote Channels	5-51
5.9.13	Trip Control	5-51
5.9.14	Polar Table Manipulation	5-54
5.9.15	Output Polar Table Value	5-54
5.9.16	Input Polar Table Value	5-56
5.9.17	Output Polar Table Type and Rating	5-56
5.9.18	Input Polar Table Type and Rating	5-57
5.9.19	Input Polar Table Wind Speed	5-57
5.9.20	Output Apparent Wind Correction Table Values	5-58
5.9.21	Input Apparent Wind Correction Table Value	5-61
5.9.22	Output Apparent Wind Correction Status	5-61
5.9.23	Enable/Disable Apparent Wind Correction	5-61
5.9.24	Input Calibration Value	5-62
5.9.25	Output Calibration Value	5-62
5.9.26	Input Damping Value	5-63
5.9.27	Output Damping Value	5-63
5.9.28	Input Hercules Channel Text	5-63

CONTENTS (Contd.)

Para		Page
5.9.29	Output Text Immediately	5-63
5.9.30	Output Alarm	5-64
5.9.31	Hercules 2000 General Purpose Input Value	5-66
5.9.32	General Purpose Output Value	5-66
5.9.33	Output from Network or NMEA	5-67
5.9.34	Input to Network or NMEA	5-68
5.9.35	NMEA Sentence Output Rate Selection	5-68
5.9.36	Displaying Performance Unit Memory	5-69
5.9.37	Displaying Software Version Numbers	5-69
5.9.38	Hercules 290/390 Commands Not Recognised by Hercules 2000	5-70
5.9.39	RS232 Error Messages	5-70
5.9.40	RS232 Command Summary	5-73
5.9.41	True Wind Correction	5-74
5.9.42	Output True Wind Correction Table Values	5-74
5.9.43	Input True Wind Correction Table Values	5-75
5.10	EXPANSION PROCESSOR	5.76
5.10.1	The Expansion Processor	5.76
5.10.2	Linear Function Settings	5.76
5.10.3	Calibrating a Linear Channel	5.77
5.10.4	Expansion Processor Wiring	5.78

ILLUSTRATIONS

Fig No		Page
5.1	Halcyon Display	5-9
5.2	20/20 CD Display	5-11
5.3	40/40 Display	5-14

TABLES

Table No		Page
5.1	Analogue Indicators Available	5-8
5.2	NMEA 0183 Input Sentence Summary	5-20
5.3	NMEA Halcyon Gyro Stabilised Compass	5-21
5.4	NMEA 0183 Output Sentence Summary	5-22
5.5	RS232 Format	5-43
5.6	Channel Numbers for 290/390 Functions	5-45
5.7	Default Channel Numbers for Remote Functions	5-46
5.8	Item Numbers for Remote Functions	5-52

TABLES (Contd.)

Table No		Page
5.9	Polar Table Example	5-53
5.10	Apparent Wind Speed Correction	5-59
5.11	Apparent Wind Angle Correction	5-60
5.12	Alarm Numbers	5-65
5.13	Hercules 2000 Function Numbers	5-71
5.14	True Wind Angle Correction Table	5-75
5.15	True Wind Speed Correction Table	5-75

(5) Press the **Page** Key. The FFD will now return to normal operation and the 20/20 CD will display the selected function.

5.4.5 Re-configuring 20/20 CD Display

In addition to the 14 pre-set functions, any one of the 20/20 CD Displays may be re-configured to show any other function available to the system. This feature allows any 20/20 CD to be set-up to show the information most useful to the user at that station in the yacht.

The procedure for re-configuring a 20/20 CD function is as follows:

- (1) At the FFD, press and hold down the **Page** Key for at least 3 seconds. The FFD will change to show the function displayed on the 20/20 CD together with the display number.
- (2) Using the **Scroll Down** Key, cycle through the 20/20 CD numbers and select the one required.
- (3) Using the **Scroll Up** Key select the function you wish to change.
- (4) Press the **Enter** Key and the function currently being displayed on the 20/20 CD will commence to flash.
- (5) Press and hold down the **Scroll Up** Key and cycle through the normal FFD Menu until the required function choice is displayed (e.g. NAVIGATE).
- (6) Press and hold down the **Scroll Down** Key until the required operational choice is displayed (e.g. COURSE).
- (7) Press the **Enter** Key to accept the selection.
- (8) Press the **Page** Key and the FFD will return to normal operation and the 20/20 CD displays the newly configured page.

5.5 40/40 DISPLAY

5.5.1 The Display

The 40/40 is a fully programmable, single function, large digit, display which may be installed anywhere in the yacht.



Fig 5.5 - 40/40 Display

5.5.2 Display Configuration

The 40/40 may be configured to repeat any function (except latitude/longitude) available on your Hercules 2000 System. It is however provided with 14 pre-set functions that may be selected by use of a remote push-button connected to the display or via any FFD on the system.

The pre-set functions are as follows:

Boat Speed	Depth m
Depth ft	Apparent Wind Speed
Apparent wind Angle	True Wind Speed
True Wind Angle	Velocity Made Good
Compass heading	Timer Count Up/Down
Bearing to Waypoint*	Course Over Ground*
Speed Over Ground*	True Wind Direction

Note

Functions marked with an * are NMEA Functions and are available only when a suitable Position Fixer is interfaced with the system.

5.5.3 Function Selection - Remote Push-Button

If a remote push-button is connected to a 40/40 display any one of the 14 pre-set functions may be selected by pressing and holding down the associated button. The display will then cycle through the functions. When the required function is displayed, release the button.

If the button is held down too long and the required function is missed, press and hold down the button again. The display will then cycle through the functions in reverse order. When the required function is displayed, release the button.

5.5.4 Function Selection - FFD

An alternative to using a dedicated remote push-button, is to control the 40/40 using any one of the standard FFDs on the system. Any 40/40 can be controlled from any FFD.

To change the function shown on a 40/40 using an FFD, proceed as follows:

- (1) At the FFD, press and hold down the **Page** Key for at least 3 seconds. The FFD display will change to show the function displayed on the 40/40 together with the display number. The selected display will start to flash.
- (2) Using the **Scroll Down** Key cycle through the 40/40 numbers and select the required display number.
- (3) Using the **Scroll Up** Key cycle through the 14 pre-set functions until the required function is displayed on the FFD. Release the **Scroll Up** Key.
- (4) If the function is missed, press and hold down the **Scroll Up** Key and the functions will cycle through in reverse order. Release the **Scroll Up** Key when the required function is displayed.
- (5) Press the **Page** Key. The FFD will now return to normal operation and the 40/40 will display the selected function.

5.5.5 Re-configuring the 40/40 Display

In addition to the 14 pre-set functions, any 40/40 pre-set function may be re-configured to show any other function available to the system. This feature allows any 40/40 to be set-up to show the information most useful to the user at that station in the yacht.

The procedure for re-configuring a 40/40 function is as follows:

- (1) At the FFD, press and hold down the **Page** Key for at least 3 seconds. The FFD will change to show the function displayed on the 40/40 together with the display number.
- (2) Using the **Scroll Down** Key, cycle through each 40/40 display in turn (display flashes) and stop at your desired choice.
- (3) Using the **Scroll Up** Key select the function you wish to change.
- (4) Press the **Enter** Key and the function currently being displayed on the 40/40 will start to flash.
- (5) Press and hold the **Scroll Up** Key and cycle through the normal FFD Menu until the required function choice is displayed (e.g. NAVIGATE).
- (6) Press and hold the **Scroll Down** Key until the required operational choice is displayed (e.g. COURSE).
- (7) Press the **Enter** Key to accept the selection.
- (8) Press the **Page** Key and the FFD will resume normal operation and the 40/40 displays the newly configured page.

5.6 GRAVITY SWITCH

In installations where two speed sensors or depth transducers are fitted a gravity change over switch can be fitted to automatically select the leeward sensor. A switch on the outside of the unit overrides the automatic selection if required, for example when calibrating the individual speed sensors.

5.7 AUDIBLE ALARM

The main processor contains a relay switch for an external audible alarm.

5.8 NMEA INTERFACE

The Hercules 2000 has an NMEA Interface which enables it to communicate with other marine electronic devices. The most important of these is the position fixer. Connecting this to the Hercules 2000 allows all the navigational information to be displayed on the FFD, and also integrates the two sets of information to produce new data such as tide rate and direction.

National Marine Electronics Association (NMEA) is the American trade association which has produced a number of standard specifications for the interconnection of marine electronic instruments. These standards specify the electrical signals and the format of data to be transferred. This allows devices such as the Hercules 2000, position fixers, autopilots and other equipment to be interconnected.

The Hercules 2000 has two NMEA inputs and outputs, (one of which cannot be used if the RS232C interface is required). These are designed to comply with the latest NMEA standards - NMEA 0183 Ver 2.20.

5.8.1 Displaying NMEA Functions

Depending on the device connected to the NMEA interface the following functions may be displayed by the Hercules System:

Bearing to waypoint, true, rhumb.	(BTW RMB T)
Bearing to waypoint, magnetic, rhumb.	(BTW RMB M)
Bearing to waypoint, true, great circle.	(BTW GC T)
Bearing to waypoint, mag., great circle.	(BTW GC M)
Bearing from waypoint to waypoint, true.	(BRG W/W T)
Bearing from waypoint to waypoint, mag.	(BRG W/W M)
Distance to waypoint, rhumb, N.Mi.	(DTW RMB NM)
Distance to waypoint, great circle, N.Mi.	(DTW GC NM)
Distance to layline, N.Mi.	(LAYLINE NM)
Course over ground, true.	(CRSE O/G T)
Course over ground, magnetic.	(CRSE O/G M)
Speed over ground in knots.	(SPD O/G KT)
Velocity made good to waypoint in knots.	(VMG WPT KT)
Time to waypoint.	(TTG WPT MS)
Cross track error Nautical miles.	(CROSS TR NM)
Local time.	(LOC TIME MS)
Universal Coordinated Time	(UTC TIME MS)

In addition there are also a number of functions that can be input through the NMEA interface that duplicate other Hercules 2000 functions. Details of all the input functions are given in Table 5.7.

The NMEA functions may be called up to display in the same manner as any Hercules 2000 function, see Part 2 - Operating Information. Most of the NMEA functions are to be found in the WAYPOINT Menu, but the time functions (LOC TIME and UTC TIME) are in the TIME Menu. Only those functions that are received by the Hercules 2000 System will appear in the display menu and it may be necessary to wait a while after the NMEA device has been switched on before the menu is complete. If no data is received for a selected function after 15 seconds then the display will show OFF.

5.8.2 Selection of Equipment

When planning the purchasing of equipment to interface to the Hercules 2000 System it is most important to check that it is NMEA 0183 compatible and the required data is transmitted or received by it.

The 0183 standard defines data sentences which are identified by three letter mnemonics. Tables 5.2 and 5.3 list the sentences and their mnemonics that are input and output by the Hercules 2000 NMEA interface. Para 5.8.10 gives the detailed information on the data and format of the sentences.

Note

If you have any doubt about your equipment compatibility then please consult your dealer.

Table 5.2 - NMEA 0183 Input Sentence Summary

Mnemonic	Description
APA	Autopilot format A
APB	Autopilot format B
BEC	Bearing and Distance to Waypoint, Great circle, Dead Reckoned.
BER	Bearing and Distance to Waypoint, Rhumb, Dead Reckoned.
BOD	Bearing to destination Waypoint from origin Waypoint.
BWC	Bearing and Distance to Waypoint, Great Circle, measured.
BWR	Bearing and Distance to Waypoint, Rhumb, measured.
BWW	Bearing to Waypoint from Waypoint.
DBT	Depth below transducer.
GDP	Dead Reckoning fix.
GGA	Global Positioning System Fix data
GLL	Latitude and Longitude.
GLP	Loran C Present Fix
HDG	Heading, Deviation and Variation
HDM	Present Heading, Magnetic
HDT	Heading, True
HVD	Magnetic Variation - Derived
HVM	Magnetic Variation Manually Set
MTA	Air Temperature, Celsius
MTW	Water Temperature, Celsius
MWD	Surface Wind Direction and Velocity
RMA	Recommended minimum implementation sentence, Loran-C specific.
RMB	Recommended minimum implementation sentence, Generic navigation information.
RMC	Recommended minimum implementation sentence, GPS, Transit specific.
VHW	Heading and Water Speed
VLW	Log mileage, water referenced
VPW	Velocity Parallel to True Wind, Device Measured
VTG	Actual Track and Ground Speed.
VWR	Wind Relative Bearing and Velocity

Table 5.2 - NMEA 0183 Input Sentence Summary (Contd.)

Mnemonic	Description
VWT	Wind True Bearing and Velocity
WBD*	Bearing and Distance to Waypoint
WCV	Waypoint Closure Velocity.
WDC	Next Waypoint Distance, Great Circle.
WDR	Next Waypoint Distance, Rhumb.
XTE	Cross Track Error, Measured.
XTR	Cross Track Error, Dead Reckoned.
ZDA	Time and Date
ZDL*	Time and Distance to Layline.
ZLZ	Local Time Zone.
ZTG	Time to Waypoint.

* not standard NMEA sentence.

Note

Brookes & Gatehouse will not necessarily extract data from every NMEA field. This avoids the same information being repeated twice on the system.

Table 5.3 - NMEA Halcyon Gyro Stabilised Compass

Mnemonic	Description
GGA	LAT, LON
GLL	LAT, LON
HDG	Heading Magnetic with variation
HDM	Heading Magnetic
HDT	Heading True
HVD	Magnetic Variation
HVM	Magnetic Variation
RMC	LAT, LON, Date & Magnetic Variation
VHW	Heading True & Magnetic
ZDA	Date

Table 5.4 - NMEA 0183 Output Sentence Summary

Mnemonic	Description
DBT	Depth Below Transducer
GLL	Latitude and Longitude
HDM	Present Heading, Magnetic
MTA	Air Temperature, Celsius
MTW	Water Temperature, Celsius
MWD	Surface Wind Direction and Velocity
VHW	Heading and Water Speed
VLW	Log Mileage, Water Referenced
VPW	Velocity Parallel to True Wind, Device Measured
VWR	Wind Relative Bearing and Velocity
VWT	Wind True Bearing and Velocity
XTE	Measured Cross Track Error

Note

Sentences are only output if data is available.

5.8.3 NMEA Input and Output Configuration

The Hercules NMEA interface has two inputs and two outputs. However if the RS232 interface is required then only one NMEA input and output can be used. The inputs are optically isolated, as required by the standard, so there is no direct electrical connection between the talker device and the Hercules System. The input requirement is half the minimum drive capacity of a standard NMEA output.

The two outputs are identical and are capable of driving at least two NMEA inputs each (four in total). If data is available then NMEA information is output once a second.

5.8.4 Changing NMEA/RS232 Configuration

Changing the NMEA/RS232 configuration is carried out by adjusting the calibration on Cross Track Error as follows:

- (1) Select Cross Track Error on the display. If a page has not already been set up to display cross track error, then it can be found by cycling through the options in the WAYPOINT Menu.
- (2) Using the **Scroll Up** and **Scroll Down** Keys scroll to "CALBRATE" on the other half of the display. Press **Enter** twice to show the current configuration number (NMEA MDE).
- (3) Press **Enter**, the configuration number flashes.
- (4) Use the **Scroll Up** and **Scroll Down** Keys to change the number as follows:

Config No.	Input 1	Output 1	Input 2	Output 2
0	183	183	RS232	RS232
1	183	183	183	183
4	183	183	183	183

The default setting is 0 for RS232 capability.

- (5) Press **Enter** to accept the new configuration.

5.8.5 Fast HDM Output Option

The two NMEA ports may be configured independently to output HDM sentences ten times a second for the benefit of other NMEA instruments that may require a rapid heading update. To set this up, proceed as follows:

- (1) Select the MISC Menu and cycle through the options to find NMEAPORT 1 or NMEAPORT 2 as appropriate.
- (2) Using the **Scroll Up** and **Scroll Down** keys scroll to CALBRATE on the other half of the display. Press **Enter** twice to show the current HDM output rate (HDM RATE HZ).

- (3) Press **Enter**, the output rate flashes.
- (4) Use the **Scroll Up** and **Scroll Down** keys to adjust the output rate: the only rates that are valid are 1 (for output once a second) and 10 (for output ten times a second).
- (5) Press **Enter** to accept the new output rate.

When fast HDM output has been selected on a given NMEA port HDM will be the only sentence output on that port.

5.8.6 True/Magnetic Reference Selection

When an NMEA heading source is used to drive the B&G network the heading data may be referenced to either true North or magnetic North. In some cases the heading source will output both types of data, and it is necessary for the user to select the desired reference. To do this, proceed as follows:

- (1) On the NAVIGATE Menu, select HEADING.
- (2) Using the **Scroll Up** and **Scroll Down** keys scroll to CALBRATE on the other half of the display. Press **Enter** twice to select CAL VAL 1 (TRUE/MAG). The current selection is shown as 0 for magnetic, 1 for true.
- (3) Press **Enter**, the TRUE/MAG selection flashes.
- (4) Use the **Scroll Up** and **Scroll Down** keys to adjust the 0/1 selection.
- (5) Press **Enter** to accept the new reference.

If on pressing **Enter** in step (2) the display shows anything other than TRUE/MAG it means that there is another heading source on the network. To eliminate the other source, go to the COURSE function (also on the NAVIGATE Menu) and select CAL VAL 1 (HDG NODE). Ensure that this is set to the node number of the Performance Unit, and then restart the instrument system. The unwanted heading source will no longer appear in the NAVIGATE menu.

When the heading reference is changed the text for the HEADING function will automatically be set to show °T or °M as appropriate. A similar change will also be made to other functions that are heading dependent, namely COURSE, TWD, REQD CRSE, DR CRSE and TIDE SET.

A similar procedure may be used to select the reference for CTS (Course To Steer), which is derived from the *Heading-to-steer to destination waypoint* field in the APB sentence. As with HEADING, the text for CTS is updated automatically when the reference is changed.

5.8.7 Handling of NMEA Alarm Conditions

Several NMEA sentences contain fields that indicate the validity of the data. For example, GLL, RMA, RMB and RMC contain a *data valid* or *navigation receiver warning* flag, and GGA contains a quality indicator.

When input sentences containing these indicators are decoded by the Performance Unit the status of the indicators is checked. If an invalid status is found then all the data in that sentence is marked as invalid when stored internally.

When output sentences are being constructed the validity of the data for each field is checked, and if any field is found to be invalid the invalid indicator is set in the output sentence.

If no valid data has been received for a period of 15 seconds the corresponding B&G function will display 'OFF'.

5.8.8 NMEA-based Data on the B&G Network

Data derived from NMEA sources is normally transmitted on the B&G network once a second. However, in the case of heading, if the incoming data is being rapidly updated the network data will be sent at up to four times a second. This allows improved performance to be obtained from the Hydra autopilot, if fitted.

5.8.9 NMEA 0183 Sentences

The following diagrams show the structure of the various NMEA sentences.

1 Autopilot format A (APA)

\$ aaAPA, A, A, x.xx, L, N, A, A, xxx, M, cccc*ss (CR) (LF)

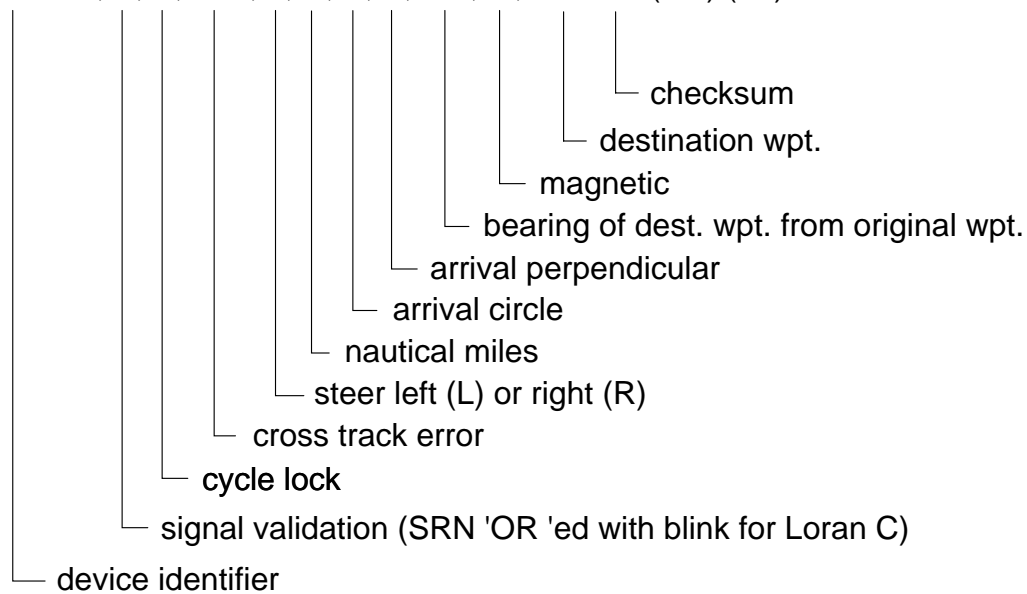

2 Autopilot format B (APB)

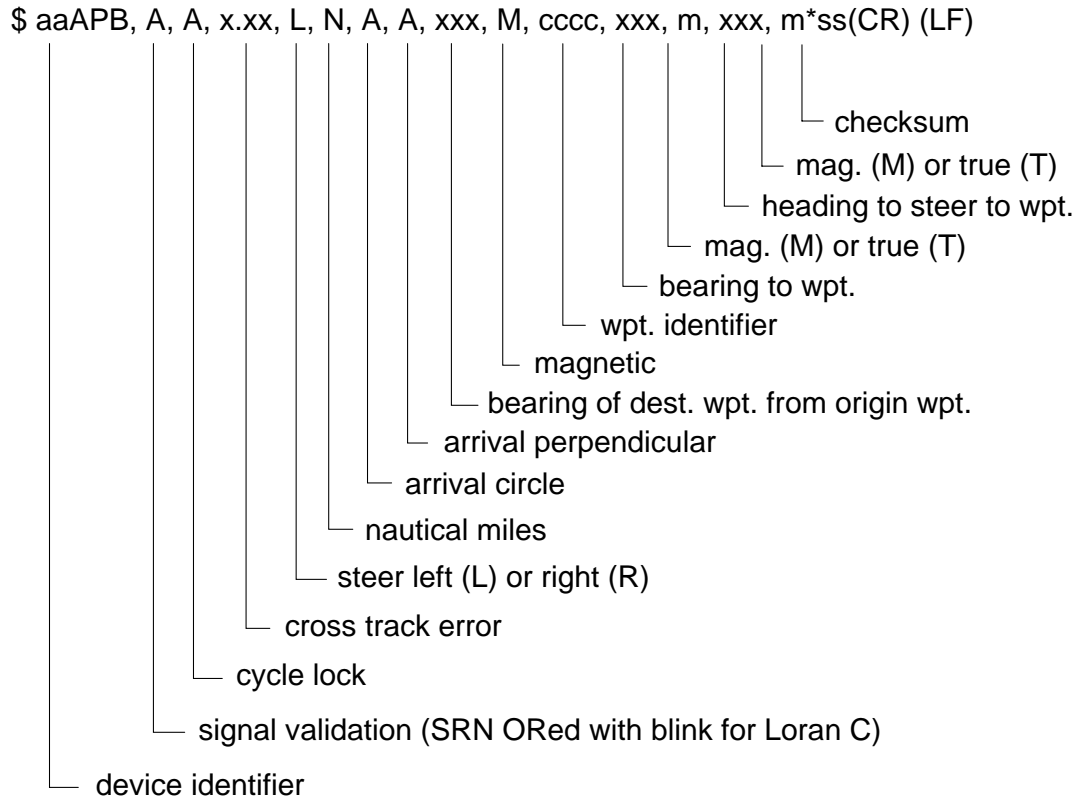

3 Bearing and distance to waypoint, great circle, dead reckoned (BEC)

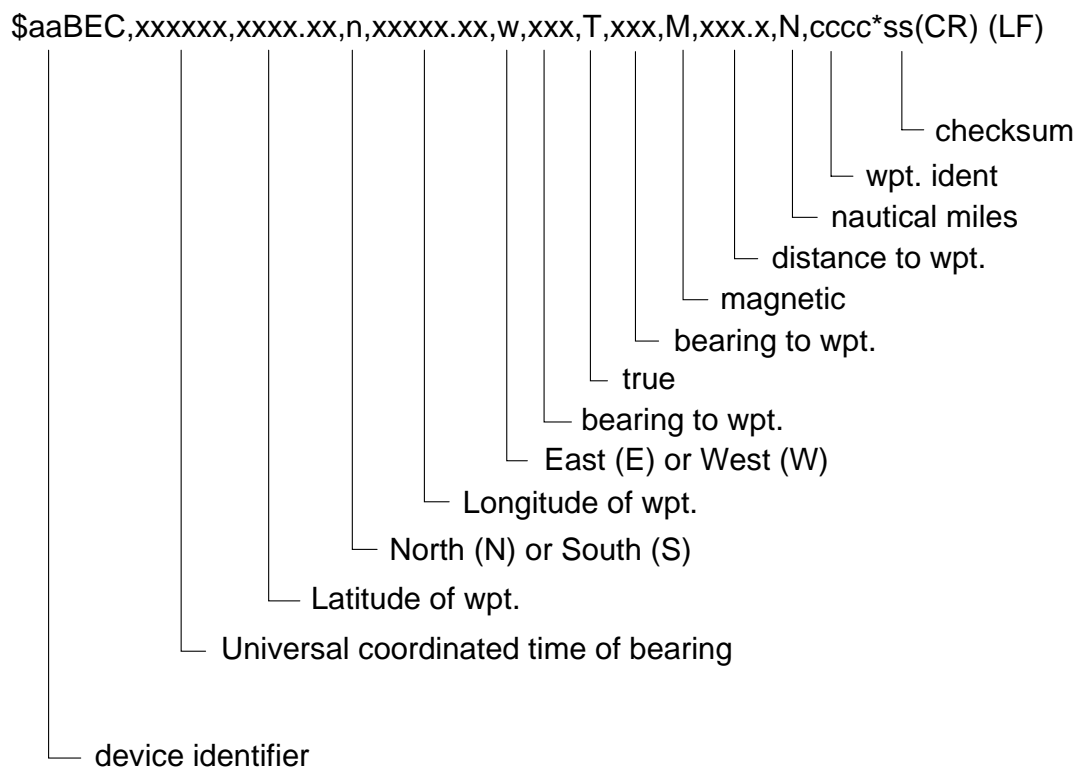

4 Bearing and distance to waypoint, rhumb, dead reckoned (BER)

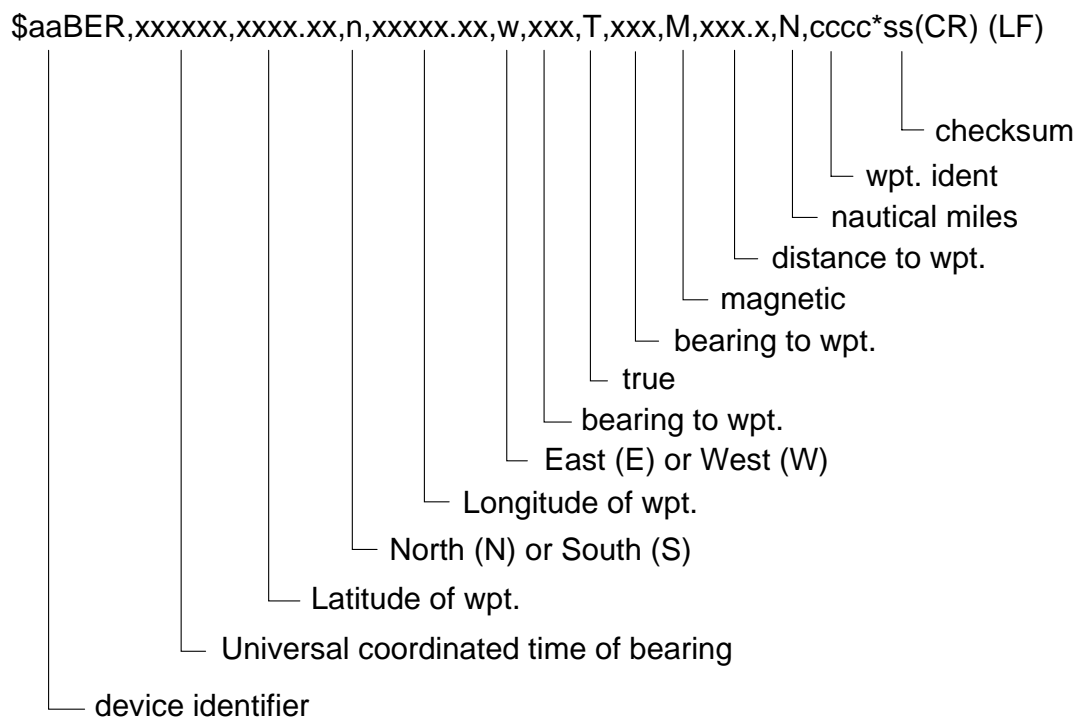

5 Bearing to destination waypoint from origin waypoint, true or magnetic (BOD)

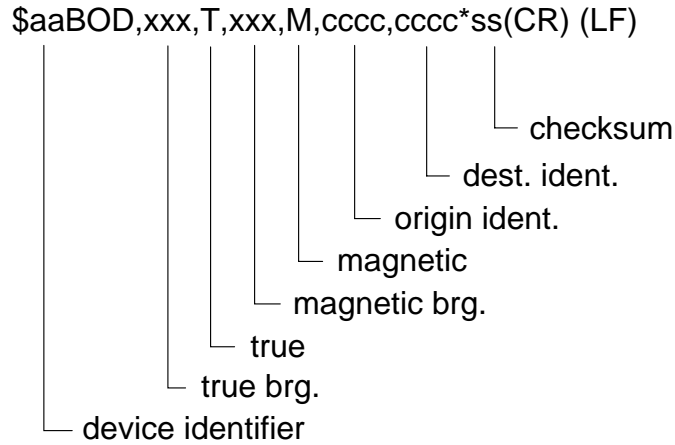

6 Bearing and distance to waypoint, great circle, measured (BWC)

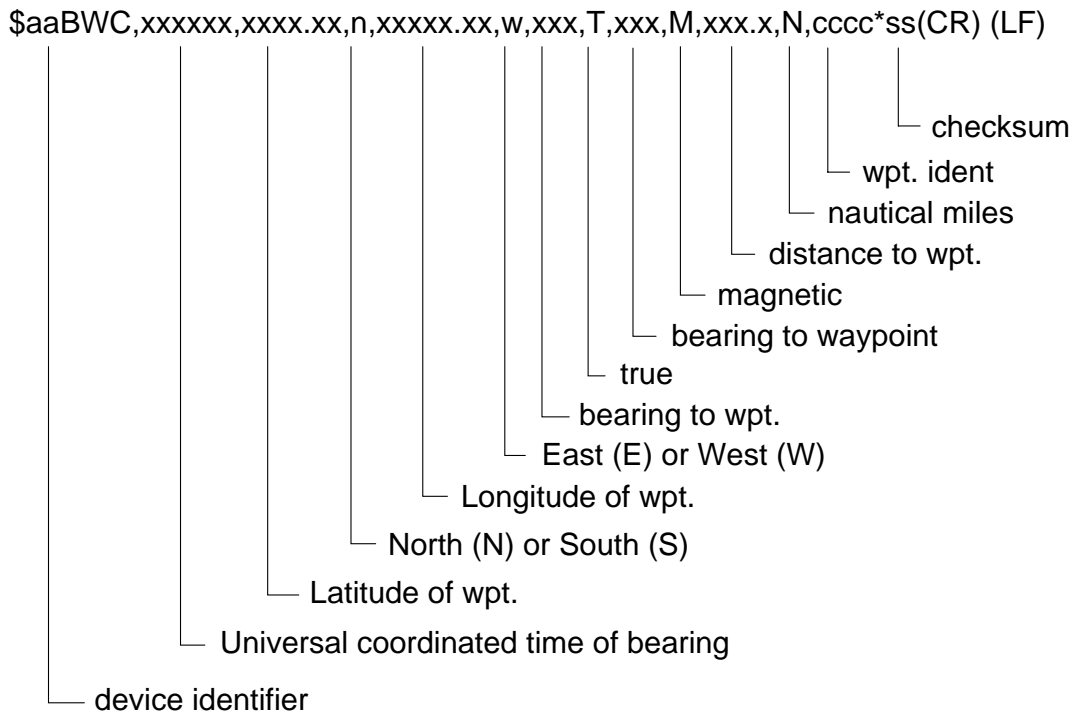

7 Bearing and distance to waypoint, rhumb line, measured (BWR)

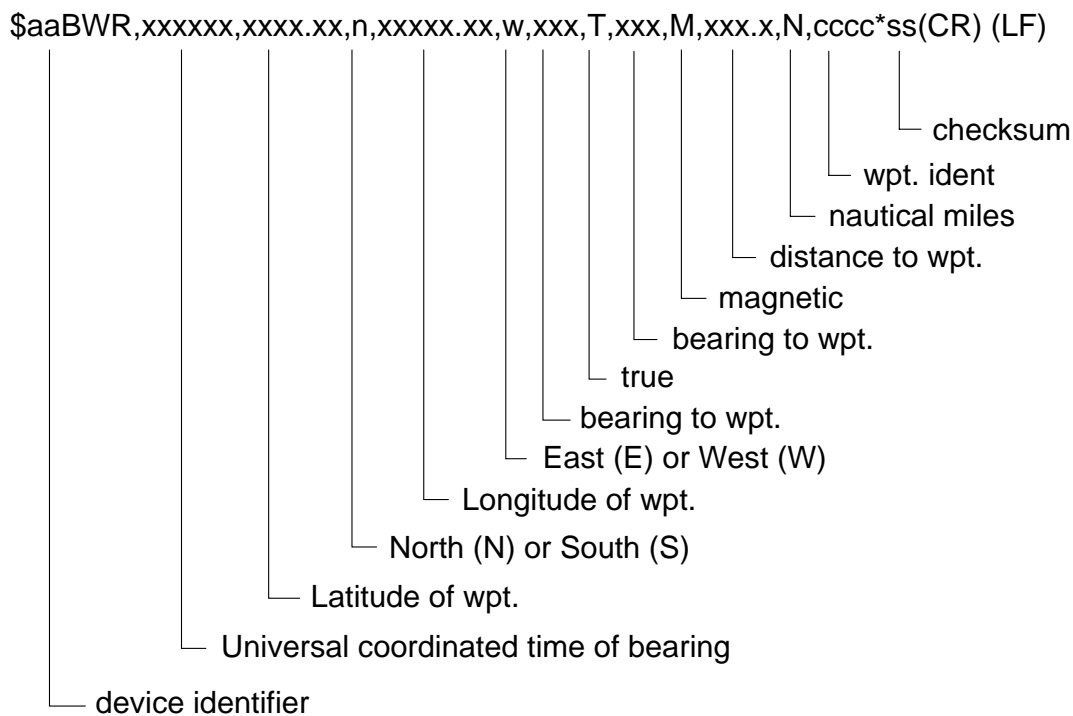

8 Bearing to waypoint from waypoint, true and magnetic (BWW)

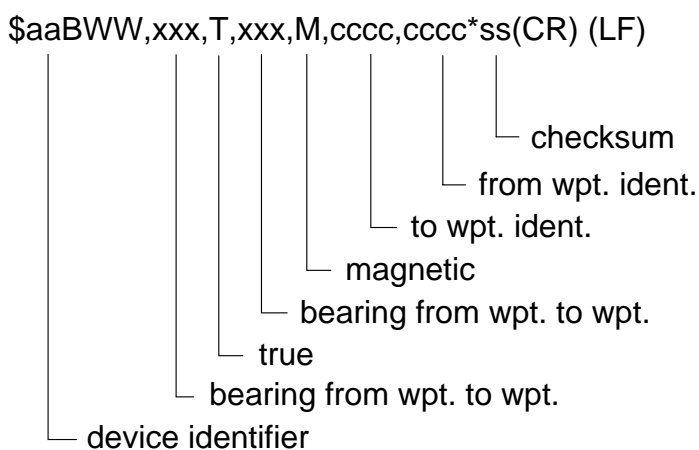

9 Depth of water below transducer (DBT)

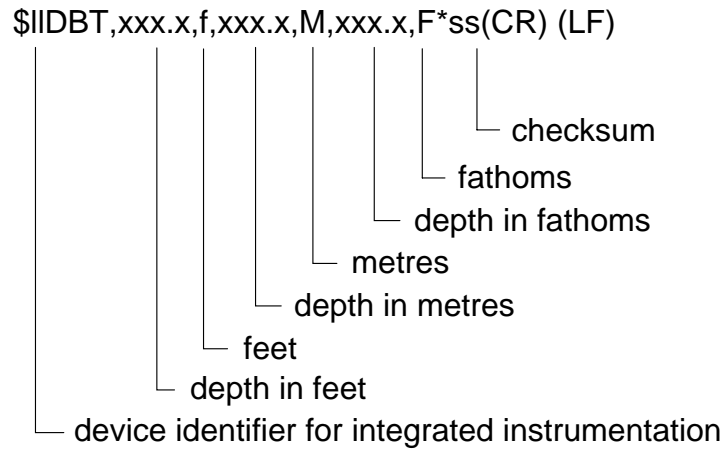

10 Present position fix, dead reckoned (GDP)

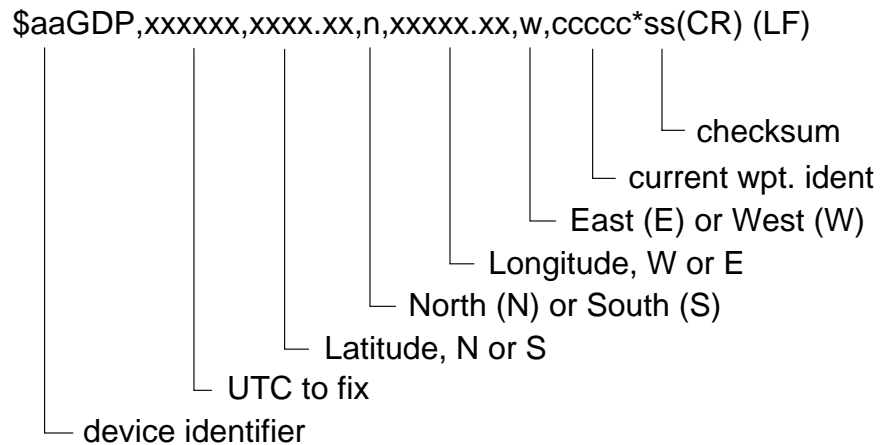

11 Global positioning fix data (GGA)

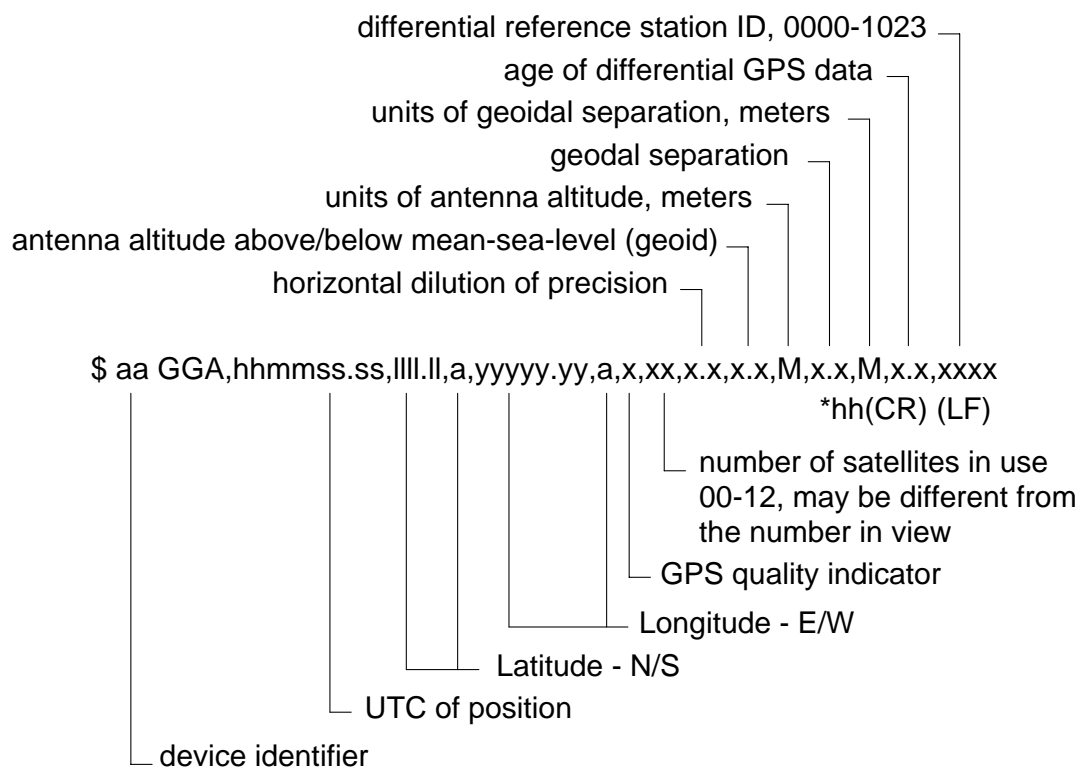

12 Present fix position (GLL)

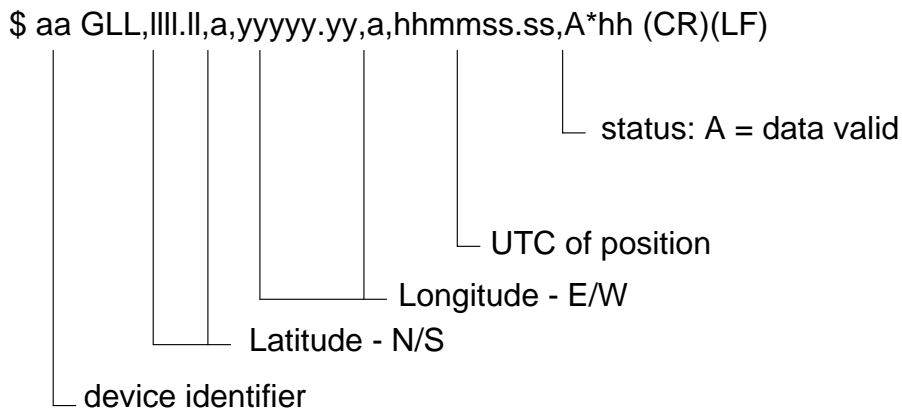

13 Present position fix, Loran -C (GLP)

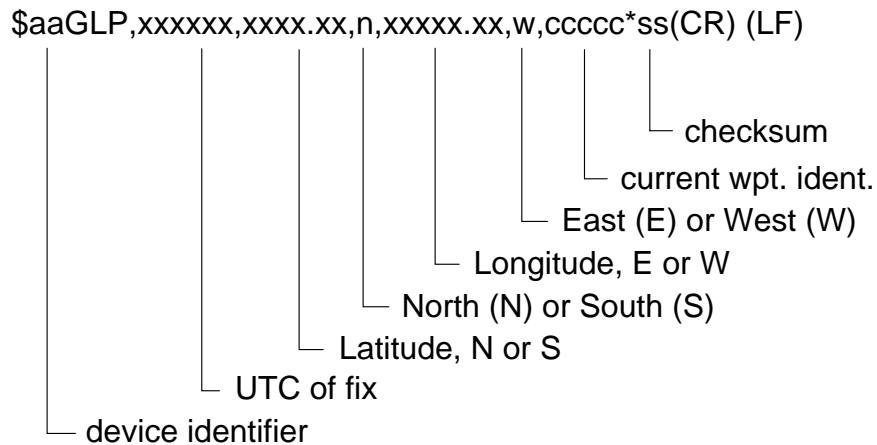

14 Heading, deviation and variation (HDG)

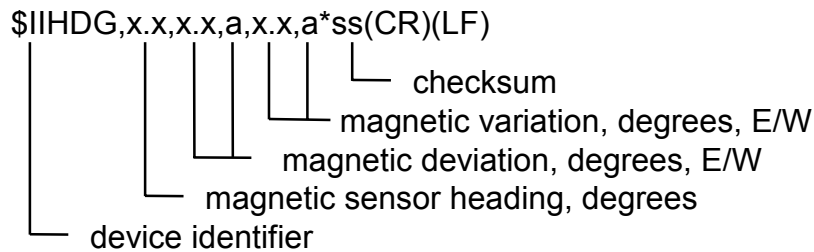

15 Present heading magnetic (HDM)

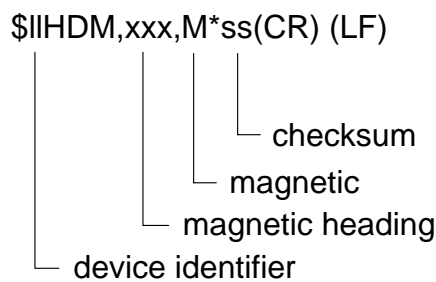

16 Heading, true (HDT)

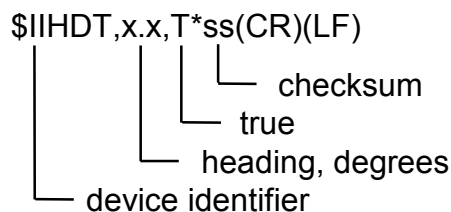

17 Air temperature, Celsius (MTA)

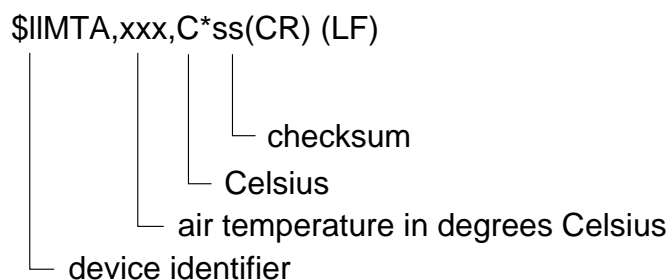

18 Water temperature (MTW)

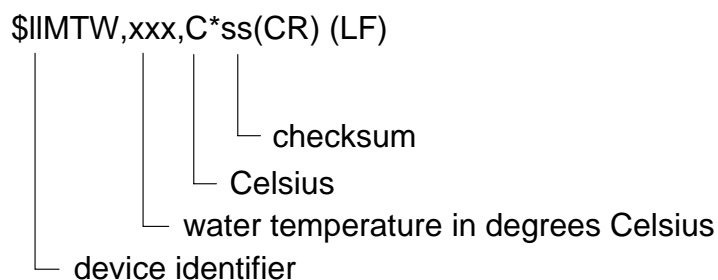

19 Surface wind, direction and velocity (MWD)

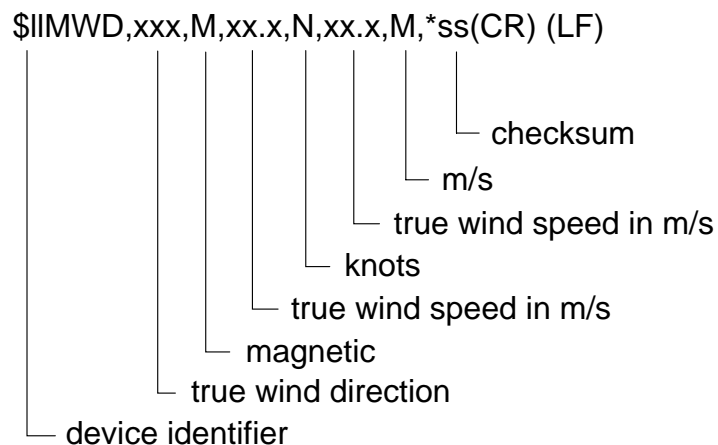

20 Recommended minimum implementation sentence, Loran -C (RMA)

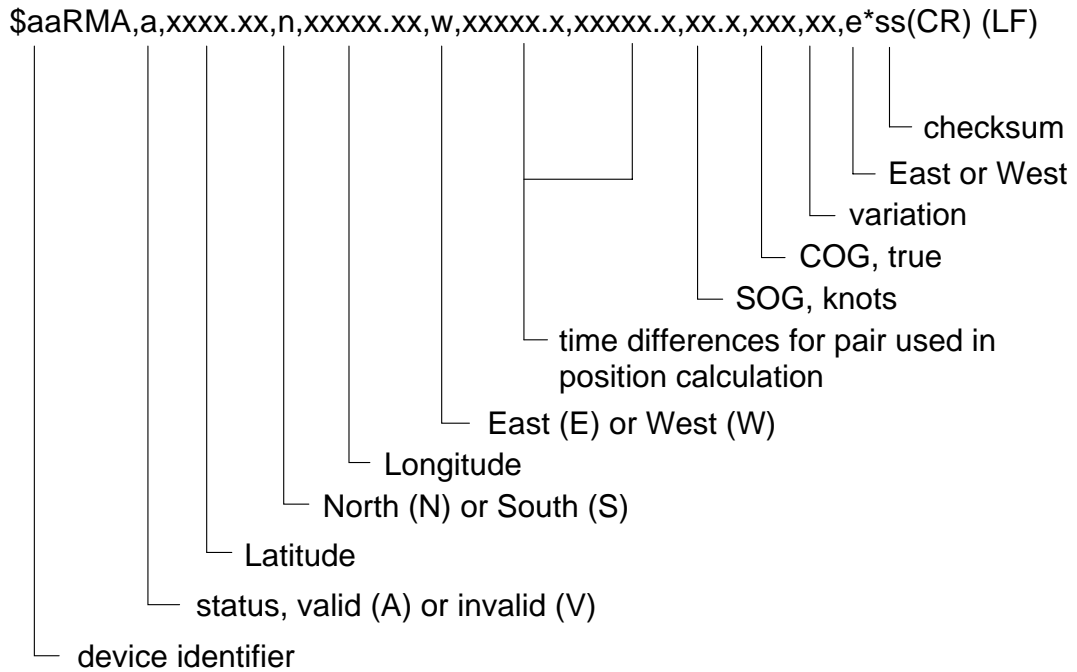

21 Recommended minimum implementation sentence, navigation information (RMB)

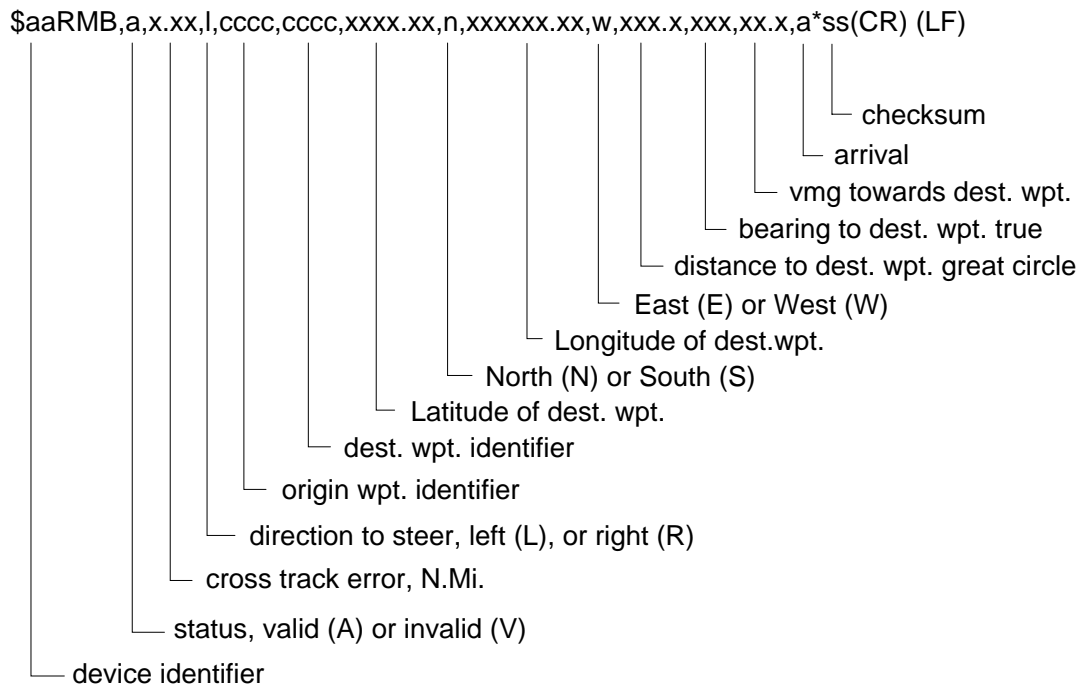

22 Recommended minimum implementation sentence, GPS or transit specific (GPS) (RMC)

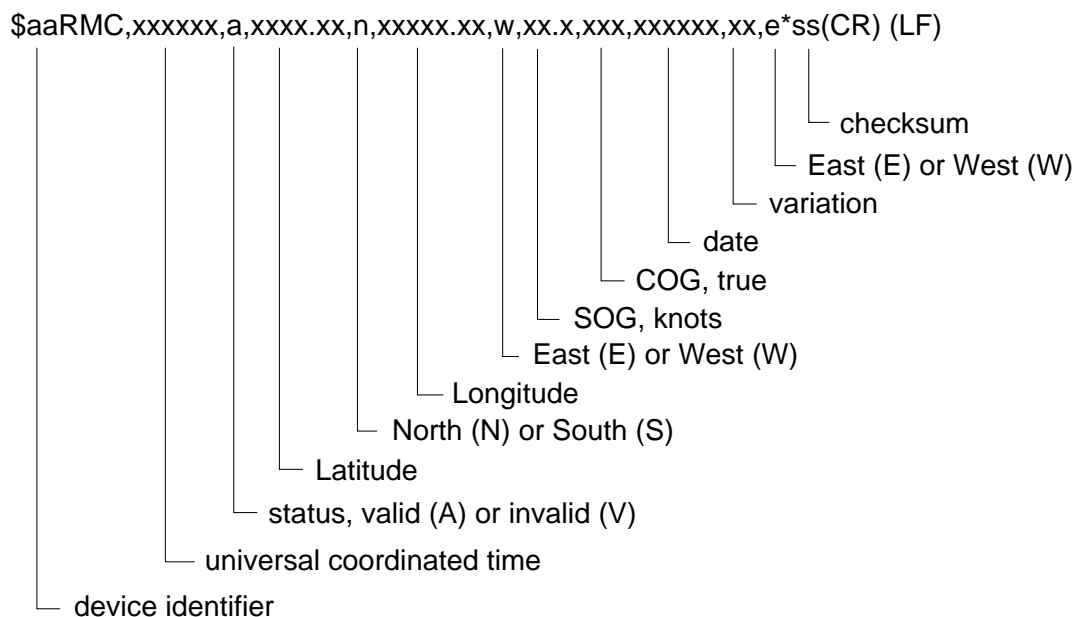

23 Water speed and heading (VHW)

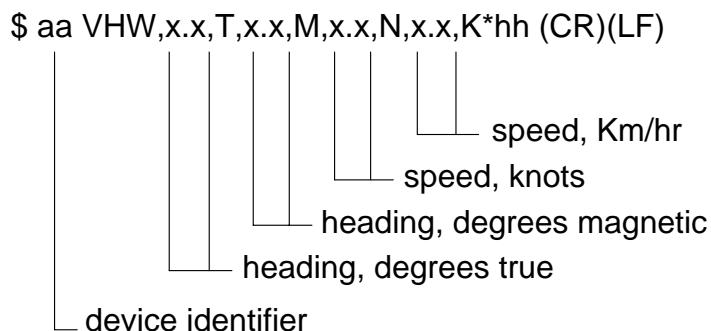

24 Water referenced log mileage (VLW)

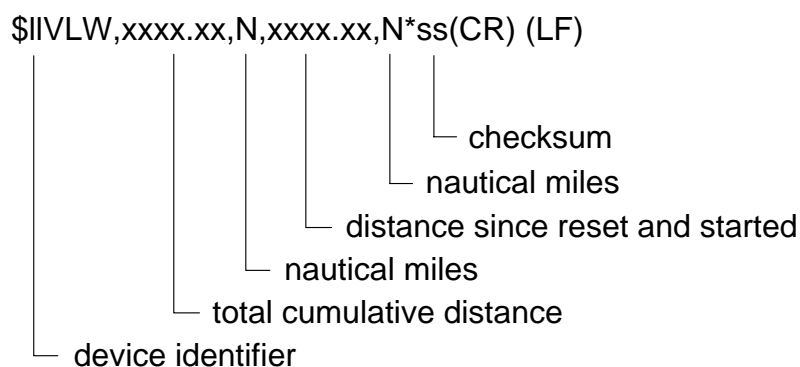

25 Device measured velocity parallel true wind (VPW)

\$IIVPW,xxx.x,N,,*ss(CR) (LF)

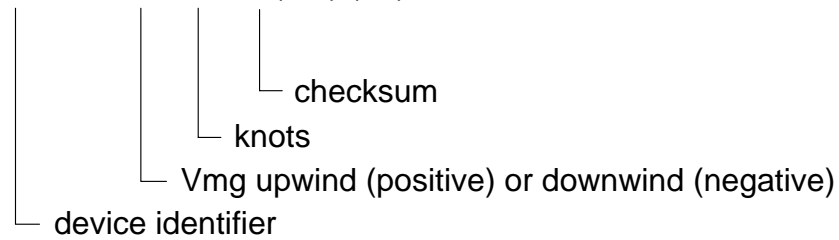

26 Actual track and ground speed (VTG)

\$ aa VTG,x.x,T,x.x,M,x.x,N,x.x,K*hh (CR)(LF)

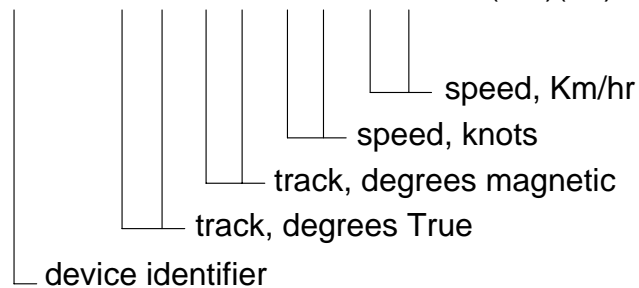

27 Wind relative bearing and velocity (VWR)

\$IIVWR,xxx,a,xx.x,N,xx.x,M,,*ss(CR) (LF)

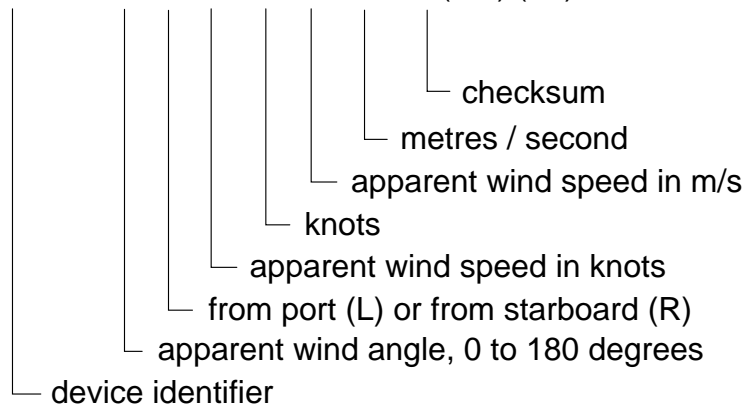

28 True wind relative bearing and velocity (VWT)

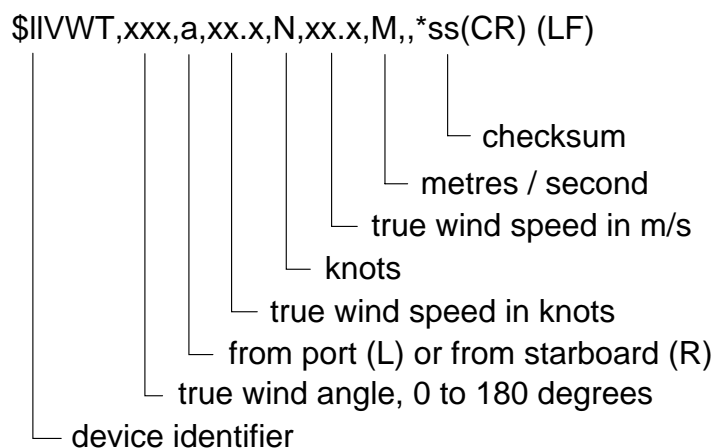

29 Waypoint closure velocity (WCV)

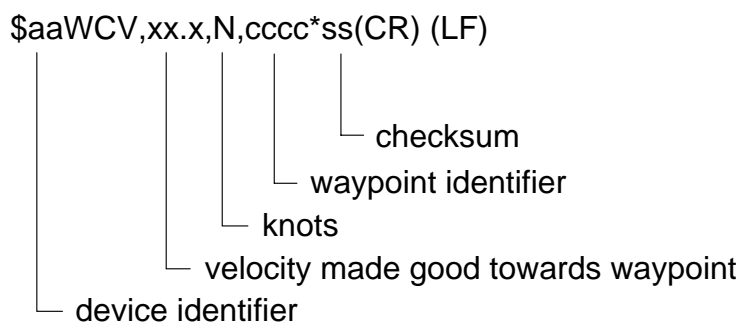

30 Distance to waypoint, great circle (WDC)

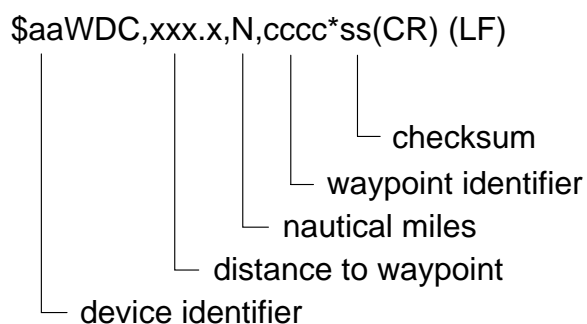

31 Distance to waypoint, Rhumb (WDR)

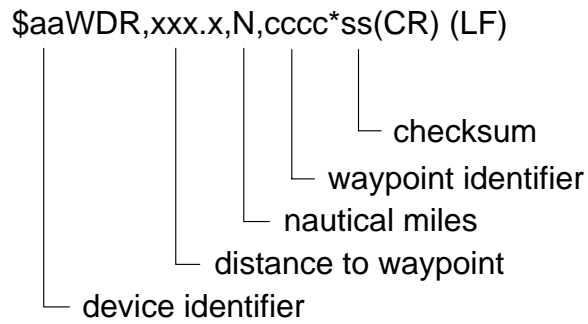

32 Measured cross track error (XTE)

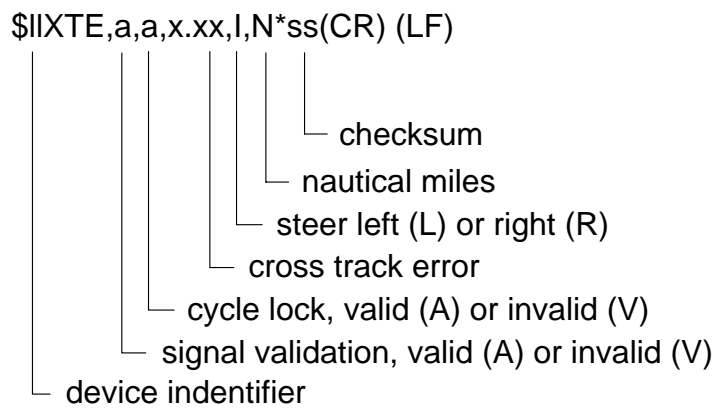

33 Dead reckoned cross track error (XTR)

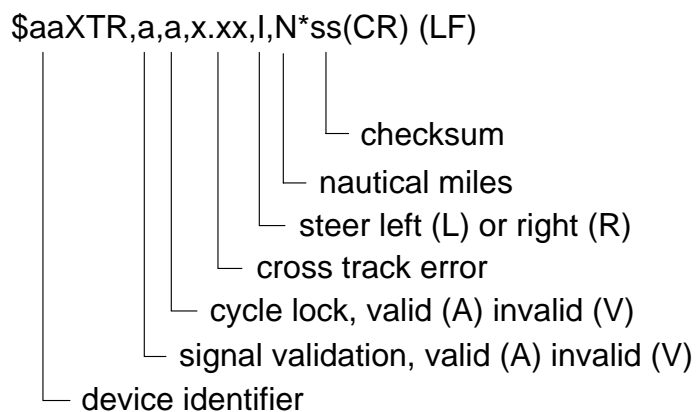

34 Time and date (ZDA)

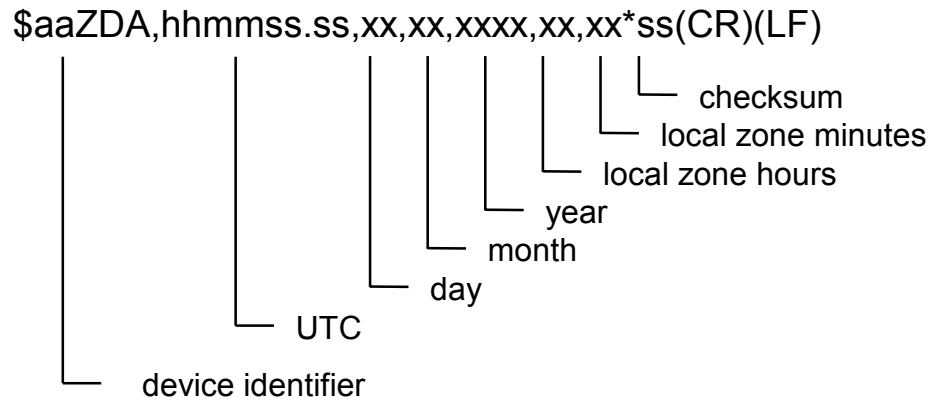

35 Time and distance to layline (ZDL)

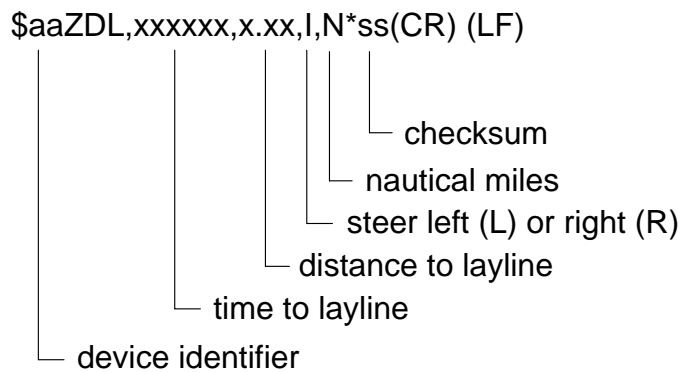

36 Time of day (ZLZ)

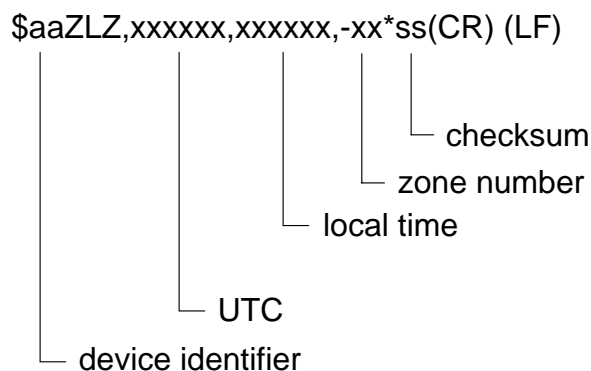

37 Time to waypoint (ZTG)

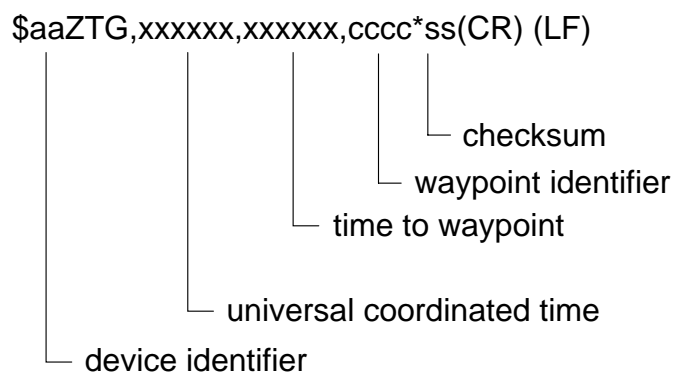

5.9 RS232 INTERFACING

The RS232C is an internationally used electrical standard for communications between computers of all different makes and sizes. It is widely used in the personal computer market to allow the transfer of files and other information between PC's or from PC's to printers. Using the RS232C interface on the Hercules 2000 you will be able to send data to an on-board tactical computer, or use a personal computer with B&G's software to update your polar tables.

The RS232C differs from the NMEA standards in that it only provides the electrical specifications and not the data format standard. Your external device will have to be programmed to send and receive the information according to the format of the B&G data. The remainder of this section is dedicated to the commands and data sentences understood by the Hercules 2000 with its RS232C port. Many of the commands have been designed to be compatible with those used in the Hercules 290 and 390 Systems. Therefore only minor changes will be required when using software designed for those systems with the Hercules 2000.

5.9.1 RS232C Input and Output Configuration

The Hercules Performance Unit has two serial input output channels, one is used just for NMEA and the other can be configured for NMEA or RS232C.

5.9.2 Changing NMEA/RS232 Configuration

Changing the NMEA/RS232 configuration is done by adjusting two calibrations on cross track error. The first of these determines if RS232C can be used and the second determines the RS232C baud rate and format.

To configure the Performance Unit for RS232C, NMEA MDE must be adjusted to 0. NMEA MDE can be found as follows:

WAYPOINT → CROSS TR,
CALBRATE → CAL VAL1 (NMEA MDE)

Full details of the meaning of other values of NMEA MDE are given in the NMEA interfacing Para 5.8.4

To adjust the RS232C baud rate and format select BAUD RTE as follows:

WAYPOINT → CROSS TR,
CALBRATE → CAL VAL2 (BAUD RTE)

The units digit is the Baud Rate as follows :

- 1 = 300 Baud
- 2 = 600 Baud
- 3 = 1200 Baud
- 4 = 2400 Baud
- 5 = 4800 Baud
- 6 = 9600 Baud
- 7 = 19200 Baud

The tenths digit controls the format for input as well as output as given in Table 5.4. The default setting is 6.2 (9600 Baud with the same Format as Hercules 290/390). All data has at least 1 stop bit.

Table 5.5 - RS232 Format

	INPUT	OUTPUT
0	8 data bits (bit 7 ignored) no parity, RTS handshake	7 data bits, even parity, CTS Handshake
1	8 data bits (bit 7 ignored) no parity, RTS handshake	7 data bits, odd parity, CTS handshake
2	7 data bits, even parity RTS handshake	7 data bits, even parity, CTS handshake
3	7 data bits, odd parity RTS handshake	7 data bits, odd parity, CTS handshake
4	8 data bits (bit 7 ignored) no parity, RTS handshake	7 data bits, even parity, no handshake (CTS ignored)
5	8 data bits (bit 7 ignored) no parity, RTS handshake	7 data bits, odd parity, no handshake (CTS ignored)
6	7 data bits, even parity RTS handshake	7 data bits, even parity, no handshake (CTS ignored)
7	7 data bits, odd parity RTS handshake	7 data bits, odd parity, no handshake (CTS ignored)

5.9.3 Command Syntax

Commands are input as a string of ASCII characters starting with a # character and a two character command mnemonic followed by data fields separated by commas. The command is terminated and execution initiated by a carriage return (CR).

A command line may not contain more than 88 characters including the start # and the terminating carriage return (CR). Data parameters may be omitted provided that if a following parameter is needed the separating commas are included.

For example:

#IR,0,,NO DATA,(CR)

Would just input the text "NO DATA" to display on remote 0.

Characters received after the terminating (CR) of a command line and before the # of the next command will be ignored. This allows comment lines to be inserted between commands if required.

5.9.4 Channel Numbers

To maintain compatibility with previous Hercules 290 and 390 Systems it has been necessary to allocate the functions that were available in 290/390 channel numbers (see Tables 5.5 and 5.6) and in the case of NMEA or remote functions have a means of changing the allocations. This is done by setting CAL VAL3 for the function to the required channel number or using the #RC,nn,cc(CR) command.

Table 5.6 - Channel Numbers for 290/390 Functions

Channel	Function	Output Rate Hz	Format
00	heel angle	1	H0.00 or 0.00H
01	boatspeed	4	,0.00 or 20.00
02	stored log	0.25	00.00
03	heading, true	2	359
04	reset log	0.25	00.00
05	heading, magnetic	2	359
06	dead reckoning	0.25	00.00 or 359
07	battery volts	0.5	12.00
08	depth feet	0.5	99.9' or 999'
09	optimum wind angle	0.5	-00 or 00
10	apparent windspeed	1	A 0.0 or A99.9
11	depth metres	0.5	30.2d or 304d
12	true windspeed	1	T 0.0 or T00.0
13	apparent wind angle	2	-179 or 00-
14	true wind angle	1	=179 or 179=
15	true wind direction	1	359.
16	reaching performance	0.5	P000
17	tacking performance	0.5	t000
18	linear 4	1	0 to 1000
19	velocity made good	1	U4.63 or D4.63
20	linear 2	1	0 or 1000
21	target boatspeed	0.5	t0.00 or 10.00
22	-	1	-
23	leeway	0.5	L 0.0 or L10.0
24	-	1	-
25	course	0.5	C000
26	linear 3	1	0 to 1000
27	sea temperature	0.25	-9.9C or 49.9 C
28	linear 1	1	0 to 1000
29	-	1	-
30	timer	1	00.00
31	-	1	-

An output rate of 0.25Hz means one reading every 4 seconds.

Table 5.7 - Default Channel Numbers for Remote Functions

Channel (default)	Function	Format
00	Remote 0	x...X
01	Remote 1	x...X
02	Remote 2	x...X
03	Remote 3	x...X
04	Remote 4	x...X
05	Remote 5	x...X
06	Remote 6	x...X
07	Remote 7	x...X
08	Remote 8	x...X
09	Remote 9	x...X
10	-	-
11	Bearing to Waypoint Rhumb True	x.xT
12	Brg to Waypoint Rhumb Magnetic	x.xM
13	Bearing to WPT Great Circle True	x.xT
14	Bearing to WPT Great Circle Mag.	x.xM
15	Distance to Waypoint Rhumb	x.x
16	Distance to Waypoint Great Circle	x.x
17	Course over ground True	x.xT
18	Course over ground Magnetic	x.xM
19	Speed over ground	x.x
20	VMG to Waypoint	x.x
21	Time to Waypoint	x.x
22	Cross Track Error	x.xL or x.xR
23	Bearing WPT to WPT True	x.xT
24	Bearing WPT to WPT Magnetic	x.xM
25	Distance to Layline	x.xL or x.xR
26	Latitude	x.xN or x.xS
27	Longitude	x.xE or x.xW
28	Tide Set	x.xT or x.xM
29	Tide Drift	dx.x or xx.x
30	Next Leg App. Wind Angle	-xxx or xxx-
31	Next Leg App. Wind Speed	x.x

5.9.5 Automatic Output Enable/Disable

#OE,nn,s,h(CR)

nn = 00 to 31 channel number
s = 0 for automatic output of channel disabled
s = 1 for automatic output of channel enabled
h = H indicates reference to Hercules channel
h = R indicates reference to NMEA or Remote channel.

The data output rate depends on the channel number, as shown in Table 5.5.

5.9.6 Automatic Output Start/Stop

#OS,s(CR)

s = 0 to stop all RS232 automatic output.
s = 1 to start all RS232 automatic output which has been enabled.

When an automatic start command is executed, all Hercules and remote channels that have been enabled using the #OE command will be output regularly.

Data for Hercules functions is output as follows:-

nn,x...x(CR)

nn = channel number (00 to 31).
x...x = ASCII data.

Data for NMEA or Remote channels is output as follows:-

rnn,x...x(CR)

nn = Remote channel number (00 to 31).
x...x = ASCII data.

Examples:

00,19.8H(CR)Heel angle
01, 8.35(CR) Boatspeed
r00,1234(CR)
r01,45.88(CR)

If no data is available for a selected channel the text 'OFF' will be substituted.

5.9.7 Input Remote Channel Data and Text

#IR,nn,a...a,c...c,d...d(CR)

nn = Remote channel number (00 to 31). This must be allocated to the REMOTE 0 - 9 function by adjusting its CAL VAL3 or using the #RC,nn,cc(CR) command.

EXTERNAL → REMOTE 0, **CALBRATE** → **CAL VAL3(CHAN NO)**

or

using the #RC,nn,cc(CR) command.

a...a = Remote channel data which will be output on the FFD or 20/20CD digits.

c...c = Text to be displayed on the FFD or 20/20CD. Up to 16 characters may be sent but only 10 are used.

d...d = Page Text, ignored (was used in 290 & 390 Systems)

If only data is to be input the command may be terminated with a (CR) after the data parameter as follows:

#IR,nn,a...a(CR)

Note

This command has no effect on remote channels currently assigned to NMEA functions.

5.9.8 Automatic Output of Basic Data

Basic data consists of the values obtained from the boatspeed, wind speed, wind angle and heading sensors without damping or calibration.

#OB,s(CR)

s = 0 for automatic output disabled

s = 1 for automatic output enabled at 2Hz

s = 2 for automatic output enabled at 4Hz

Sets or resets automatic output flag for basic raw data. Automatic output is started using the #OS,1(CR) command. Basic data is then output every half second as follows:

B,w...w,x...x,y...y,z...z(CR)

www.w = Boatspeed in Hz uncalibrated, 5 characters

xxx.x = Apparent Windspeed in Hz uncalibrated, 5 characters.

yyy.y = Apparent Wind Angle in degrees no offset, 5 characters

zzz.z = Heading in degrees no offset, 5 characters

If #OS,2(CR) is used basic data will be output every quarter of a second.

5.9.9 Immediate Output of Basic Data

#OB(CR)

This command stops all automatic output of other data and outputs basic data immediately. Data is output using the same format as automatic output of basic data.

Note

After automatic data has been stopped by this command it can be restarted using the #OS,1(CR) command.

5.9.10 Immediate Output of Channel or Remote Data

#OI,nn,s(CR)

nn = channel number 00 to 31. For NMEA and Remote 0 to 9 functions channel numbers must be allocated by setting CAL VAL3 on those functions or using the #RC,nn,cc(CR) command. Table 5.5 gives the channel numbers for other functions.

s = 0 (or H) for Hercules data output

s = 1 (or R) for NMEA or Remote data output

This command stops all other automatic output, and outputs as follows:

Inn,xxxxx(CR) - Hercules data requested
Rnn,xxxxx(CR) - if remote data requested
nn = channel number
xxxx = data (see Tables 5.5 and 5.6 for examples).

Note

If Hercules data is required, s may be omitted and the command will be:

#OI,nn(CR)

If remote data is required, the command will be:

#OI,nn,1(CR)

Note

After automatic output has been stopped by an output immediate command it can be re-started using the #OS,1(CR) command.

Examples	I00,H19.8	Heel angle	channel 00
	I01,21.35	Boatspeed	channel 01
	I10,A9.9	Apparent wind speed	channel 10
	I14,179=	true wind angle	channel 14

5.9.11 Output Latitude and Longitude

#OL(CR)

Stops all other automatic output and outputs the last value for latitude and longitude received via NMEA as follows:

L,ddmm.hhh,n,dddmm.hhh,e(CR)
 | |
 latitude longitude
dd = degrees
mm = minutes
hhh = hundredths of minutes
n = n for north or s for south
e = e for east or w for west

#OL,s(CR)

s = 0 for automatic output of lat. and long. disabled.
s = 1 for automatic output of lat. and long. enabled.

Automatic output must be started using the #OS,1(CR) command.

5.9.12 Assign Remote Channels

#RC,nn,cc(CR)

nn = 00 to 31 Remote channel number
cc = Item number, see Table 5.7

5.9.13 Trip Control

#TC,t,l,d(CR)

t = 0,-5,-10,-15 to start Timer Countdown
= 1 to leave Timer running or unfreeze
= 2 to freeze Timer
l = 0 to reset Trip Log to zero
= 1 to start Trip Log or leave running
= 2 to freeze Trip Log
d = 0 to reset Dead Reckoning to zero
= 1 to start Dead Reckoning or leave running
= 2 to freeze Dead Reckoning

#TC(CR)

Stops automatic output and returns the current states as follows:

S,t,l,d,(CR)

Table 5.8 - Item Numbers for Remote Functions

Item Number	Remote Function
01	Bearing to Waypoint True Rhumb
02	Bearing to Waypoint Magnetic Rhumb
03	Bearing to Waypoint True Great Circle
04	Bearing to Waypoint Magnetic Great Circle
05	Distance to Waypoint Rhumb
06	Distance to Waypoint Great Circle
07	Course Over Ground True
08	Course Over Ground Magnetic
09	Speed Over Ground
10	VMG to Waypoint
11	Time to Waypoint
12	Cross Track Error
13	Bearing Waypoint to Waypoint, True
14	Bearing Waypoint to Waypoint, Magnetic
15	Distance to Layline, Nautical Miles
16	Latitude
17	Longitude
18	Tide Set, Magnetic
19	Tide Drift
20	Next leg Apparent Wind Angle
21	Next leg Apparent Wind Speed
22	Remote 0
23	Remote 1
24	Remote 2
25	Remote 3
26	Remote 4
27	Remote 5
28	Remote 6
29	Remote 7
30	Remote 8
31	Remote 9

Table 5.9 - Polar Table Example

		TRUE WIND SPEED IN KNOTS									
	TRUE WIND ANGLE	4.0	6.0	8.0	10.0	12.0	14.0	16.0	18.0	20.0	22.0
02	20	1.56	2.70	3.57	4.10	4.50	4.80	5.00	5.20	5.50	5.40
03	30	1.87	3.04	4.04	4.88	5.30	5.66	5.95	5.99	6.15	6.20
04	40	2.08	3.29	4.40	5.49	5.99	6.54	6.78	6.87	6.86	6.75
05	50	2.13	3.52	4.67	5.90	6.50	6.95	7.23	7.33	7.35	7.29
06	60	2.19	3.75	4.95	6.09	6.69	7.07	7.36	7.45	7.51	7.50
07	70	2.10	3.83	5.22	6.18	6.79	7.22	7.48	7.58	7.67	7.72
08	80	2.02	3.91	5.40	6.27	6.88	7.30	7.61	7.73	7.89	7.95
09	90	2.00	3.90	5.45	6.31	7.02	7.45	7.74	7.88	8.11	8.18
10	100	1.98	3.85	5.40	6.39	7.10	7.59	7.87	8.03	8.30	8.39
11	110	1.99	3.76	5.26	6.39	7.11	7.65	7.96	8.19	8.40	8.50
12	120	1.97	3.65	5.08	6.30	7.06	7.65	8.00	8.30	8.43	8.53
13	130	1.90	3.50	4.90	6.00	6.87	7.51	7.96	8.21	8.36	8.48
14	140	1.87	3.25	4.60	5.67	6.67	7.38	7.80	8.10	8.28	8.42
15	150	1.84	3.01	4.20	5.23	6.30	7.04	7.56	7.93	8.19	8.37
16	160	1.80	2.80	3.90	4.80	5.80	6.60	7.20	7.70	8.05	8.27
17	170	1.75	2.60	3.65	4.50	5.50	6.31	6.96	7.53	7.93	8.22
18	180	1.70	2.40	3.42	4.30	5.29	6.02	6.83	7.44	7.88	8.17
19	OPTIMUM VMG	1.80	2.85	3.79	4.34	4.69	5.00	5.23	5.33	5.37	5.32
20	OPT TWA U/W	40	39	38	37	36	35	34.5	34	34	33.5
21	OPTIMUM VMG	1.80	2.70	3.70	4.80	5.80	6.20	6.80	7.40	7.80	8.10
22	OPT TWA D/W	157	158	160	161	162	163	165	168	170	172

5.9.14 Polar Table Manipulation

A special set of RS232 commands are available for the manipulation of polar performance data. Using these commands it is possible to read and adjust individual elements of the polar table or scale the whole polar table.

An example of the polar table format is shown in Table 5.8. The syntax and function of each command is as described in the following Paragraphs.

5.9.15 Output Polar Table Value

#PO,s,nn(CR)

s = single digit number between 0 and 9 which represents a row in the Polar Table (see Table 5.8). Each row of the table has a true wind speed associated with it.

nn = two digit value between 02 and 22 which represents a column in the Polar Table.

Rows 02 to 18 represent true wind angles from 20 to 180 degrees in increments of 10 degrees.

Row 19 represents the optimum upwind VMG.

Row 20 represents the true wind angle associated with 19.

Row 21 represents the optimum downwind VMG.

Row 22 represents the true wind angle associated with 21.

Issuing this command will cause the following message to be output:

P,xx.x,yy.yy(CR)

where:

xx.x = three digit value representing true wind speed associated with row 's' of polar table

yy.yy = boatspeed in knots if 'nn' = 02-18

optimum upwind VMG in knots if 'nn' = 19

true wind angle associated

with above if 'nn' = 20

optimum downwind VMG in knots if 'nn' = 21

true wind angle associated

with above if 'nn' = 22

Example:

The command **#PO,3,08(CR)** will cause the message:

P,10.0,07.25(CR) to be output.

```

|   |
true boat
wind speed
speed

```

Likewise command **#PO,4,20(CR)** will cause the message:

P,12.0,042(CR) to be output.

```

|   |
true true
wind wind
speed angle

```

The command may also be used to output a complete row, or the entire table, by omitting one or more parameters. For example, the command:

#PO,3(CR)

will cause the whole of row 3 to be output in the format:

PR,r,cc,uu.u,cc,vv.vv,...cc,vv.vv,cc,ww.ww,cc,xxx,cc,yy.yy,cc,zzz

where

r	is the row number (0..9)
cc	is the column number (01..22)
uu.u	is the true wind speed set for this row
vv.vv	is the boat speed
ww.ww	is the optimum upwind vmg
xxx	is the true wind angle for upwind vmg
yy.yy	is the optimum downwind vmg
zzz	is the true wind angle for downwind vmg

Because output lines can only be a maximum of 80 characters it takes several lines to output a complete row. Each line begins with

PR,r,cc....

to indicate which row and column follows.

In a similar way, the command:

#PO(CR)

outputs the entire table, row by row, in the above format.

5.9.16 Input Polar Table Value

#PI,s,nn,yy.yy(CR)

s = 0 - 9 (as in previous command)

nn = 02 - 22 (as in previous command)

This command permits any single element of the polar table to be changed.

Example:

The command **#PI,7,05,07.45(CR)**

Will cause the polar table element corresponding to a wind speed of 20 knots and a true wind angle of 50 degrees to be changed from 7.40 Knots to 7.45 Knots.

Likewise command **#PI,0,22,150(CR)**

Will cause the true wind angle associated with the optimum down wind VMG in a true wind speed of 4.0 knots to be changed from 130 degrees to 150 degrees.

5.9.17 Output Polar Table Type and Rating

The command **#PR(CR)**

Will cause the current polar table type and its associated rating to be output in the following format:

W,s,xx.xx(CR)

s = single digit 0, 1, 2 or 3 representing the polar table type currently being used.

xx.xx = Four digit number between 16.50 and 99.99 representing the IOR rating. This rating value is used when the entire polar table is scaled.

5.9.18 Input Polar Table Type and Rating

The command **#PR,s,xx.xx(CR)**

This command selects a polar table from the three available in the Performance Unit and then scales it for a new rating value.

s = Polar table type (0, 1 or 2) to be selected. All adjustments to the previously selected polar table will be lost. If the 's' parameter is omitted then the currently selected polar table will be adjusted to the new rating value.

xx.xx = four digit number between 16.50 and 99.99 Representing the IOR rating. When a new rating is entered using this command, all the elements (apart from optimum angles) will be scaled in the following way:

$$\text{New value} = \text{old value} \times \sqrt{\frac{\text{new rating}}{\text{old rating}}}$$

Each of the three polar tables stored within the Performance Unit has its own associated default rating value:

TYPE	NO.	RATING
Masthead rig	0	26.20 IOR rated feet
Fractional rig	1	22.50 IOR rated feet
ULDB	2	29.50 IOR rated feet

5.9.19 Input Polar Table Wind Speed

#PW,s,xx.x(CR)

This command permits values in the wind speed column of the currently selected Polar Table to be altered.

s = single digit value 0 to 9 representing a row in the Polar Table (see Table 5.8)

xx.x = wind speed in knots of 00.0 to 99.9

Notes

1. It is important that the wind speeds in the polar table lie in ascending order, i.e. $s = 0$ corresponds to the smallest wind speed value, $s = 9$ corresponds to the largest wind speed value. If, by using the #PW command, the wind speed values become disordered then 'Err 5' will be displayed on Reaching and Tacking performance.
2. Duplicate non-zero values for wind speed must not exist in the wind speed column of the polar table. If duplicate values are introduced using the PW command then 'Err 6' will be displayed on Reaching and Tacking performance.
3. If less than ten Wind Speeds are required, the first values must be set to zero.

5.9.20 Output Apparent Wind Correction Table Values

The Hercules 2000 contains two tables that can be used to correct the measured apparent wind values which are to be used in further calculations. These do not affect the values of apparent wind speed or apparent wind angle displayed. Table 5.9 is an example of the apparent wind speed correction table and Table 5.10 is an example of the apparent wind angle table.

#TO,s,nn(CR)

$s = 1$ to 6 row number for 5,10,15,20,25 and 30 knots Apparent Windspeed respectively.

$nn = 01$ to 24 column number. Columns 01 to 12 are for 20, 25, 30, 35, 40, 60, 80, 100, 120, 140, 160 and 180 degrees Apparent Wind Angle respectively and contain apparent wind speed correction values. Columns 13 to 24 for 20, 25, 30, 35, 40, 60, 80, 100, 120, 140, 160 and 180 degrees Apparent Wind Angle respectively and contain apparent wind angle correction values.

The command stops all automatic output and returns:

U,s,nn,y...y(CR)

if $nn = 01$ to 12

yy.yy or -yy.yy = Windspeed correction value in knots

if $nn = 13$ to 24

yyy.y or -yyy.y = Wind Angle correction value in degrees.

The command may also be used to output a complete row, or the entire wind correction table (including the true wind correction values described in Para 5.8.42), by omitting one or more parameters. For example:

#TO,3(CR)

outputs the whole of row 3 in the format:

UR,r,cc,-ww.ww,...cc,-xxx.x,...cc,-yyy.y,...cc,zz.zz

where r is the row number (1..6)
cc is the column number (01..28)
ww.ww is the apparent wind speed correction
xxx.x is the apparent wind angle correction
yyy.y is the true wind angle correction
zz.zz is the true wind speed correction

In general, these values can be either +ve or -ve. Negative values will be preceded by a minus sign.

Because output lines can only be a maximum of 80 characters it takes several lines to output a complete row. Each line begins with

UR,r,cc....

to identify the row and column of the data that follows.

Table 5.10 - Apparent Wind Speed Correction

nn		01	02	03	04	05	06
AWA		20	25	30	35	40	60
s	Wind Speed						
1	5	-0.65	-0.40	-0.20	-0.10	-0.10	-0.20
2	10	-0.30	-0.10	0.20	0.20	0.10	-0.30
3	15	-1.20	-0.90	-0.45	-0.45	-0.45	-0.75
4	20	1.00	0.60	0.20	0.00	-0.40	-0.60
5	25	1.25	1.00	1.00	1.25	1.25	2.00
6	30	1.50	1.50	1.80	2.40	3.00	4.50

nn		07	08	09	10	11	12
AWA		80	100	120	140	160	180
s	Wind Speed						
1	5	-0.45	-0.60	-1.10	-0.75	-0.70	-0.60
2	10	-0.70	-1.10	-1.50	-1.50	-1.20	-0.80
3	15	-1.35	-1.95	-1.80	-1.65	-1.05	-1.05
4	20	-0.80	-1.20	-1.20	3.00	-0.60	-0.20
5	25	2.75	3.25	3.00	2.50	1.50	0.00
6	30	6.60	7.20	6.60	5.80	3.60	0.00

Table 5.11 - Apparent Wind Angle Correction

nn		13	14	15	16	17	18
AWA		20	25	30	35	40	60
s	Wind Speed						
1	5	-1.0	-2.0	-4.0	-4.5	-5.0	-6.0
2	10	-2.0	-4.5	-6.5	-7.5	-8.5	-8.5
3	15	-0.5	-0.5	-4.5	-5.5	-6.5	-7.5
4	20	0.0	-1.0	-3.0	-4.0	-5.0	-6.0
5	25	0.0	-0.5	-2.0	-3.0	-4.0	-5.0
6	30	0.0	0.0	-1.0	-2.0	-3.0	-4.0

nn		19	20	21	22	23	24
AWA		80	100	120	140	160	180
s	Wind Speed						
1	5	-7.0	-8.0	-7.5	-6.0	-4.5	0.0
2	10	-12.0	-14.0	-12.0	-10.5	-8.0	0.0
3	15	-8.5	-9.5	-8.5	-6.5	-4.0	0.0
4	20	-7.0	-8.0	-5.5	-12.0	-2.0	0.0
5	25	-6.0	-7.0	-4.0	-2.0	-1.0	0.0
6	30	-5.0	-6.0	-3.0	-1.0	0.0	0.0

5.9.21 Input Apparent Wind Correction Table Value

#TI,s,nn,y...y(CR)

s = 1 to 6 row number as in previous command.

nn = 01 to 24 column number as in previous command.

yy.yy or -yy.yy = Windspeed correction value in knots

yyy.y or -yyy.y = Wind Angle correction value in degrees.

This command permits any single element of the correction tables to be changed.

5.9.22 Output Apparent Wind Correction Status

#OC,15(CR)

This command will stop automatic output and reply with:

C,15,s(CR)

s = 0 for no corrections being applied to apparent wind values.

1 for corrections being applied to apparent wind values for use in further calculations.

5.9.23 Enable/Disable Apparent Wind Correction

#IC,15,s(CR)

s = 0 for no correction to be applied to apparent wind values.

1 for correction to be applied to apparent wind values used in further calculations.

5.9.24 Input Calibration Value

#IC,n,x...x(CR)

n = calibration number
 x...x = calibration value

n	Calibration Type	Data Format	Max Value
1	Boatspeed (port)	x.xx	9.99
2	Boatspeed (stbd)	x.xx	9.99
3	Windspeed Hz/kt	x.xx	9.99
4	MHU Angle	xxx.x	359.9
5	Leeway	xx.x	99.9
6	True Wind Correction	ignored	
7	Zero Correction Angle	ignored	
8	Max Mast Twist	ignored	
9	Max Twist Angle	ignored	
10	Windspeed offset	x.xx	9.99
11	Depth datum m	xx.x	99.9
12	Depth datum ft	xx.x	99.9
13	Depth datum fm	xx.x	99.9
14	Compass offset	xxx.x	359.9
15	Apparent wind correction	x	2
16	Magnetic Variation	xxx.x	359.9
17	Next Leg Bearing	xxx.x	359.9
18	Tide On N/L Select	x	1

5.9.25 Output Calibration Value

#OC,n(CR)

n = calibration number as above

This command stops all automatic output and returns

C,n,x...x(CR)

5.9.26 Input Damping Value

#ID,n,xx(CR)

n = damping number
1 Boatspeed Damping
2 Heading Damping
3 Apparent Windspeed Damping
4 Apparent Wind Angle Damping
5 True wind speed damping
6 True wind angle damping
7 Tide Damping in minutes
xx = damping value in seconds (minutes if tide) 0 to 99.

5.9.27 Output Damping Value

#OD,n(CR)

n = damping number as in previous command.

This command stops all automatic output and returns

D,n,xx(CR)

xx = damping value 0 to 99

5.9.28 Input Hercules Channel Text

#IT,nn,c...c,d...d(CR)

nn = 00 to 31 - Hercules Channel Number (see Table 5.6)
c...c = channel text, up to 16 characters (only 10 displayed)
d...d = Page Text, ignored by Hercules 2000.

5.9.29 Output Text Immediately

#OT,nn,h(CR)

nn = 00 to 31 channel number
h = H for Hercules channel (see Tables 5.5 & 5.6)
R for NMEA or Remote channel.

Note

Remote channel numbers must be allocated by adjusting CAL VAL3 for the required function or using the #RC,nn,cc(CR) command.

This command stops all automatic output and outputs text as follows (page text is returned as spaces)

HT,nn,c...c, (CR) if Hercules channel text requested
RT,nn,c...c, (CR) if Remote Text requested.

5.9.30 Output Alarm

#OA,nn(CR)

nn = alarm number, see Table 5.11

This command stops all automatic output, and returns

Ann,xxxx,s(CR)

nn = Alarm Number
xxxx = Alarm Value
s = 0 for alarm OFF
s = 1 for alarm ON and not active
s = 3 for alarm ON and active

Table 5.12 - Alarm Numbers

Alarm No.	Description
01	Boatspeed High Alarm
02	Boatspeed Low Alarm
03	Heading Clockwise Alarm (calculated from Alarm Value and Sector Width)
04	Heading Anti-Clockwise Alarm (calculated from Alarm Value and Sector Width)
05	Apparent Wind Speed High Alarm
06	Apparent Wind Speed Low Alarm
07	Apparent Wind Angle Clockwise (calculated from Alarm Value and Sector Width)
08	Apparent Wind Angle Anti-Clockwise (calculated from Alarm Value and Sector Width)
09	Battery Volts High Alarm
10	Battery Volts Low Alarm
11	Depth Feet High Alarm
12	Depth Feet Low Alarm
13	Depth Fathoms High Alarm
14	Depth Fathoms Low Alarm
15	Depth Metres High Alarm
16	Depth Metres Low Alarm
17	Sea Temperature Centigrade High Alarm
18	Sea Temperature Centigrade Low Alarm
19	Sea Temperature Fahrenheit High Alarm
20	Sea Temperature Fahrenheit Low Alarm
21	Air Temperature Centigrade High Alarm
22	Air Temperature Centigrade Low Alarm
23	Air Temperature Fahrenheit High Alarm
24	Air Temperature Fahrenheit Low Alarm

5.9.31 Hercules 2000 General Purpose Input Value

#IV,nnn,mmm,fff,xx.xx,ttttttttt(CR)

nnn = node number to which value is to be sent

1	-	Depth Board
5 to 8	-	Wind Boards
9 to 12	-	RS232 or NMEA Board
255	-	Broadcast to all Boards

mmm = message type to be used

211	-	Calibration Value 1
212	-	Calibration Value 2
213	-	Calibration Value 3
214	-	Calibration Value 4
206	-	Damping Value
34	-	High Alarm Value
33	-	Low Alarm Value
32	-	Sector Alarm Value
1	-	Data Value
2	-	New text for an existing function

fff = function number see Table 5.12

xx.xx = Value value to be sent, or node number of function fff if mmm=2

ttttttttt = function text displayed on FFD or 20/20CD

This is a general purpose command for inputting values to other nodes.

5.9.32 General Purpose Output Value

#OV,nnn,mmm,fff,s(CR)

nnn = number of node from which value is to be obtained.

1	for Depth Board
5 to 8	for Wind Board
9 to 12	for RS232 or NMEA Board
13 to 16	for Expansion Boards
17 to 18	for Pilot Boards
255	for Broadcast to all Boards

mmm = message type to be used

211	-	Calibration Value 1
-----	---	---------------------

212	-	Calibration Value 2
213	-	Calibration Value 3
214	-	Calibration Value 4
206	-	Damping Value
34	-	High Alarm Value
33	-	Low Alarm Value
32	-	Sector Alarm Value
1	-	Data Value

fff = function number of value to be sent

s = 0 to inhibit automatic output
1 to allow automatic output

This is a general purpose command for getting values from any node (including the Performance Unit itself) and replies with the value as follows:

Vnnn,mmm,fff,xx.xx(CR)

xx.xx = value

5.9.33 Output from Network or NMEA

#NO,s,a?cd@eeffgg??@ijkl....(CR)

s = 0 for network data
1 for NMEA 1 data

a?cd@eeffgg??@ijkl is a mask for the network or NMEA message.

Any number of bytes 0 to 80 can be specified in the mask.

@ indicates that the characters following are in Hex (00 to FF) until another @ reverts the format back to ASCII.

Any @ or (CR) characters do not form part of the mask.

? in ASCII or ?? in hex mode allows any value for a particular byte and should be used to fill the mask up to the end of the message. If a message is received on the network or NMEA which satisfies this mask, it is output on RS232 in ASCII or hex as follows:

Nsabcd@eeffgghh@ijkl....(CR)

Characters with hex code 20H to 3FH and 41H to 7FH are output in ASCII, but for other codes, @ is sent to signify following characters are output in Hex (00 to FF), @ is sent again if other characters can be output in ASCII.

5.9.34 Input to Network or NMEA

#NI,s,@aabbccdd@efgh(CR)

s = 0 to output on Hercules 2000 network
1 to output on NMEA 1

@aabbccdd@efgh.... is the message to be output.

@ indicates all characters following are in Hex (00 to FF) until another @ reverts the format back to ASCII. Any @s and the terminating (CR) do not form part of the message output. Up to 80 characters can be output.

Network messages have the following format:

destination source count type data.....

NMEA data should include all the sentence including the starting \$ and the terminating (CR)(LF).

5.9.35 NMEA Sentence Output Rate Selection

#NS,p,fff,r(CR)

can be used to set the output rate of a specified NMEA sentence, where:

p is the NMEA port number, 1 or 2
fff is the three-character NMEA sentence formatter
r is the desired output rate in Hz

Example:

#NS,1,HDM,10(CR)

sets the output rate of HDM on port 1 to ten times a second.

At present the only sentence formatter that is recognised is HDM, and the output rates can only be 0, 1, or 10. An output rate of 0 turns HDM off.

5.9.36 Displaying Performance Unit Memory

#RM,ss,ff
#RM,ssss,ffff

outputs the contents of the Performance Unit's memory in hexadecimal notation, where:

ssss is the desired start address
ffff is the desired end address

The output format is:

Maaaa dd dd dd dd dd dd dd dd dd dd dd dd dd dd dd dd(CR)

where aaaa is the address of the first data value
dd are the data values at successive addresses

If the end address is omitted a set of 16 values is output, beginning at the start address. If the end address is more than 16 bytes from the start additional lines of up to 16 data values will be output until the end address is reached.

5.9.37 Displaying the Software Version Number

#RV,nn(CR)

causes the software version number of node nn to be output in the format:

RV,nn,vv(CR)

where nn is the node number
vv is the version number (in hexadecimal)

Example:

#RV,9(CR)

gives

RV,9,75(CR)

if version 7.5 software is fitted to the Performance Unit.

Not all Hercules units respond to version number requests, so some nodes will return version 00.

5.9.38 Hercules 290/390 Commands Not Recognised by Hercules 2000

The following commands which were available in Hercules 290/390 systems are no longer recognised, and will draw an **ERROR 01: command not recognised** response if used:

Data Destination:

#DD,nn,s(CR)

Display Text:

#DT,c...c(CR)

Keyboard Enable/Disable:

#KE,n(CR)

Output Keyboard:

#OK(CR)

5.9.39 RS232 Error Messages

If a command is incorrectly entered or has a parameter out of range then an error message of the following form will be output on RS232:

***ERROR nn: <text>(CR)**

nn = error number

<text> = a text message describing the error

The error numbers are as follows:

01 = Invalid command mnemonic

02 = Command line too long, greater than 80 characters

03 = Invalid command syntax, missing parameter

04 = Invalid parameter

05 = Parity error

06 = Channel Number out of range

Table 5.13 - Hercules 2000 Function Numbers

Air Temperature degrees C	29
Air Temperature degrees F	28
Apparent Wind Angle	81
Apparent Wind Angle, raw	82
Apparent Wind Speed knots	77
Apparent Wind Speed m/s	79
Apparent Wind Speed, raw	78
Average Speed	100
Barometric Pressure	135
Barometric Pressure Trend	134
Battery Volts	141
Bearing to Waypoint, G.C. mag.	230
Bearing to Waypoint, G.C. true	229
Bearing to Waypoint, rhumb mag.	228
Bearing to Waypoint, rhumb true	227
Bearing Wpt. to Wpt., mag.	225
Bearing Wpt. to Wpt, true	224
Boatspeed	65
Boatspeed, raw	66
Course	105
Course Over Ground, Mag.	234
Course Over Ground, True	233
Cross Track Error	238
Dead Reckoning Course	211
Dead Reckoning Distance	129
Depth Meters	193
Depth Feet	194
Depth Fathoms	195
Depth Sounder Receiver Gain	54
Depth Sounder Noise	55
Distance to Waypoint, G.C.	232
Distance to Waypoint, Rhumb	231
Fore/Aft Trim	155
Heading	73
Heading, Raw	74
Heading on Next Tack	154
Head/Lift Trend	39

Table 5.13 - Hercules 2000 Function Numbers (Contd.)

Heel Angle	52
Leeway	130
Linear 1	56
Linear 2	57
Linear 3	58
Linear 4	59
Mast Angle	156
Next Leg Apparent Wind Angle	111
Next Leg Apparent Wind Speed	113
Off Course	41
Optimum Wind Angle	53
Reaching Performance	51
Remote 0	239
Remote 1	240
Remote 2	241
Remote 3	242
Remote 4	243
Remote 5	244
Remote 6	245
Remote 7	246
Remote 8	247
Remote 9	248
Rudder Angle	11
Sea Temperature degrees °C	31
Sea Temperature degrees °F	30
Speed Over Ground	235
Stored Log	205
Tacking Performance	50
Target Boatspeed	125
Tidal Set	132
Tidal Drift	131
Timer	117
Time to Waypoint	237
Trip Log	207
True Wind Angle	89
True Wind Direction	109
True Wind Speed, knots	85

Table 5.13 - Hercules 2000 Function Numbers (Contd.)

True Wind Speed M/S	86
Vel. Made Good, Course	236
Velocity Made Good	127
Wind Angle to the Mast	157

5.9.40 RS232 Command Summary

#IC,n,x..x	Input calibration value
#ID,n,XX	Input damping value
#IR,nn,a...a,c...c	Input remote channel data and text
#IT,nn,c....c	Input text for Hercules channel
#IV,nnn,mmm,fff,xx.xx,t...t	Input Value
#NI,s,a...	Send network or NMEA message
#NO,s,a...	Output from network or NMEA
#NS,p,fff,r	NMEA output rate selection
#OA,nn	Output alarm
#OB	Output Basic Data Immediately
#OB,s	Automatic output of basic data enable/disable
#OC,n	Output calibration
#OD,n	Output damping value
#OE,nn,s,h	Automatic output enable /disable
#OI,nn,s	Output data immediately
#OL	Output Latitude and Longitude
#OS,s	Start/stop automatic output
#OT,nn,h(R)	Output text immediately
#OV,nnn,mmm,fff	Output value
#PI,s,nn,xx.xx	Polar input
#PO,s,nn	Polar output
#PR	Output table selection and rating
#PR,s,xx.xx	Input table selection and rating
#PW,s,xx.x	Enter polar windspeed
#RC,nn,cc	Assign remote channel
#RM,ssss,ffff	Display performance unit memory
#RV,nn	Display software version number
#TC,t,l,d	Trip Control
#TC	Output trip status
#TO,s,nn	Output wind correction
#TI,s,nn,y...y	Input wind correction

5.9.41 True Wind Correction

There are two tables that are used to correct the values of true wind angle and true wind speed before output to the display or use in calculation of true wind direction. These are the values that can be adjusted via the FFD when calibrating true wind angle and speed and are explained in Part 3 - Calibration

5.9.42 Output True Wind Correction Table Values

#TO,s,nn(CR)

s = 1 to 6 row number for 5,10,15,20,25 and 30 knots true wind speed respectively.

nn = 25 to 28 column number. Columns 25 to 27 contain the true wind angle correction values for Upwind, Reaching and Downwind sectors respectively. Column 28 contains true wind speed correction values for 180 degrees down wind. The wind speed correction values are interpolated to 0 at 90 degrees.

The command stops all automatic output and returns:

U,s,nn,y...y(CR)

if nn = 25 to 27
yyy.y or -yyy.y = True wind angle correction value degrees.

if nn = 28
yy.yy or -yy.yy = True wind speed correction value in knots.

5.9.43 Input True Wind Correction Table Values

#Tl,s,nn,y...y(CR)

- s =1 to 6 row number as in previous command.
- nn =25 to 28 column number as in previous command.
- yy.yy or - yy.yy =True wind speed correction value in knots
- yyy.y or - yyy.y =True wind angle correction value in degrees.

Table 5.14 - True Wind Angle Correction Table

Wind Angle	True Wind Speed					
	5	10	15	20	25	30
Correction at 180°						

Table 5.15 - True Wind Speed Correction Table

Wind Angle	True Wind Speed					
	5	10	15	20	25	30
Upwind						
Reaching						
Downwind						

5.10 EXPANSION PROCESSOR

5.10.1 The Expansion Processor

The Expansion Unit can be connected to the Hercules 2000 System via the Fastnet to drive four extra analogues (meters 5,6,7 and 8), and provide extra analogue inputs.

A new menu automatically appears on all FFD's called EXPAND when an Expansion Processor is added to the system. Up to twelve linear functions may be displayed numbered LINEAR 5 to LINEAR 16. Initially only LINEAR 5 is shown. A linear function by default shows a number between 0, representing 0 volts on its input and 1000 representing 6.5 volts on its input. The voltage change is assumed to be linear in relationship. Hence an external sensor, for example a load cell giving a linear change in voltage as the load increases, may be connected to a linear input.

LINEAR 5 has four calibration values, other linear functions have three calibration values found by selecting CALBRATE on the appropriate linear function.

5.10.2 Linear Function Settings

Altering calibration value 1 (CAL VAL 1) allows the correct input sensor to be selected. The different inputs available are shown below:

1 or 2	normal linear input 0 to 1000
3	rotating mast correction for apparent wind angle
4	heel angle input
5	trim angle input
6	barometric pressure
7	rudder angle
8	air temperature

The default factory setting for a linear input is 1 (0-1000 format).

Note

Do not set different linear inputs to the same function (except 1 for normal linear input) or the calibration value will be ignored. This ensures that no function uses no more than one analogue input. However, any one of the Linear 1 to 4 inputs from the main processor may be set to the same function as any one of the Linear 5 to 16 inputs.

Calibration value 2 (CAL VAL 2) displays MIN VAL with a number that can be adjusted between -999 and 9999. This is the number to be displayed for a 0V input. The default setting is 000.

Calibration value 3 (CAL VAL 3) displays MAX VAL with a number that can be adjusted between -999 and 9999. This is the number to be displayed for 6.5V input. The default setting is 1000.

5.10.3 Calibrating a Linear Channel

Adjusting the MIN and MAX values allows the displayed value to be scaled to the appropriate range for the sensor attached. Taking a load cell for example, if the zero load output is 0V, MIN VAL=000 and if maximum load is 650 kgF at 6.5V then MAX VAL=650.

Calibration value 4 is only available on Linear 5 and this displays a value between 05 and 16. This setting determines the number of linear inputs that are available. For example, changing this value to 10 would display a maximum of 10 linear inputs. The default value is 05.

Damping is adjustable between 00 and 99 seconds. The default setting is 01.

Notes

1. When calibration value 1 is changed to select a desired input sensor, the linear value is no longer updated and a constant value is displayed until the page key is pressed.
2. Extra functions selected, and then removed, remain in the display menu but with no data shown until the system is switched off and then back on again.
3. Linear functions will always be shown if selected by CAL VAL 4 on linear 5. They will shown no data if the CAL VAL 1 is set to 1 or 2.

5.10.4 Expansion Processor Wiring

The Expansion Processor is connected to the system Fastnet for power and data requirements.

TERMINAL	FUNCTION	WIRE COLOUR
1	Meter 5 SIN	Green
2	Meter 5 COS	Blue
3	Meter 6 SIN	Red
4	Meter 6 COS	Violet
5	Meter 7 SIN	Red
6	Meter 7 COS	Violet
7	Meter 8 SIN	Green
8	Meter 8 COS	Blue
9	Meter Lighting	Yellow
10	Meter Common	Orange
11	Meter Ground	Black
12	N/C	
13	N/C	
14	Network Data -ve	Green
15	Network Data +ve	White
16	Network Screen	Screen
17	Battery Supply Ground	Black
18	Battery Supply 12V	Red
19	Battery Volts Sense	Link to 18
20	N/C	
21	Ground	Blue
22	Sensor Supply +6.5V	Red
23	Linear 5 Input	Green
24	Linear 6 Input	Green
25	Linear 7 Input	Green
26	Linear 8 Input	Green
27	Linear 9 Input	Green
28	N/C	
29	N/C	
30	N/C	
31	N/C	
32	N/C	
33	N/C	
34	N/C	
35	N/C	
36	N/C	

TERMINAL	FUNCTION	WIRE COLOUR
37	Linear 10 Input	Green
38	N/C	
39	Linear 11 Input	Green
40	Linear 12 Input	Green
41	+12V Switched Supply	Red
42	Linear 13 Input	Green
43	+6.5V Sensor Supply	Red
44	RPM Input	Green
45	Ground	Blue
46	Linear 14 Input	Green
47	Linear 15 Input	Green
48	Linear 16 Input	Green