

Log transducer



Installation Manual English





This manual is written for NX2 Log transducer 1.00
Edition: September 2002

Mounting instruction Nexus/Star log/temp transducer

CONTENTS:

1. General
2. Part specification
3. Location of the paddle wheel transducer
4. installing the through-hull fitting
5. Connection to instrument/contacts
6. Calibration
7. Technical data
6. Warranty

1 GENERAL

The log/temp transducer is an impeller transducer installed through the hull and designed to meet the requirements of owners of sailing crafts and power boats.

2 PART SPECIFICATION

- 1# Mounting instruction
- 1# Warranty card
- 1# Paddlewheel transducer
- 1# Dummy plug
- 1# Silicone grease
- 4# O-ring
- 1# Through-hull fitting with nut
- 1# Locking device
- 5# Extra cable protectors (0,25 mm)
- 5# Extra cable protectors (0,75 mm)

3. CORRECT LOCATION OF PADDLEWHEEL TRANSDUCER

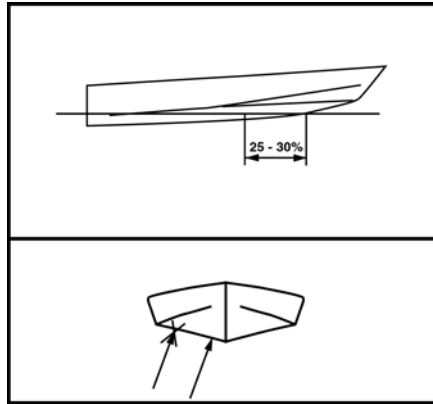

Generally the transducer should be placed as far forward as possible along the waterline length and close to the centreline.

It is important that the transducer is always in the water, within the whole speed range of the boat. Please note that the actual waterline length of fast power boats shortens considerably at high speeds. Therefore the transducer should be placed at 25-35% along the true waterline from the bow, when at full speed

Example:

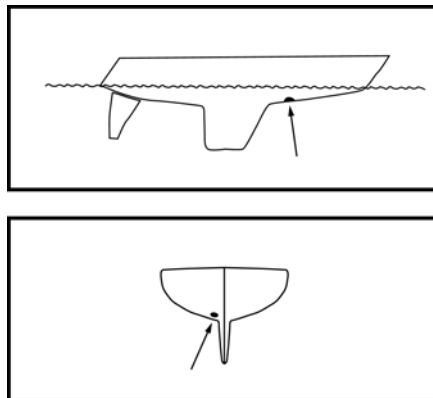

Sailboats with a fin keel must have the transducer located at least 25 cm but not more than 75 cm in front of the keel. It should be placed no more than 10 cm off the centreline.

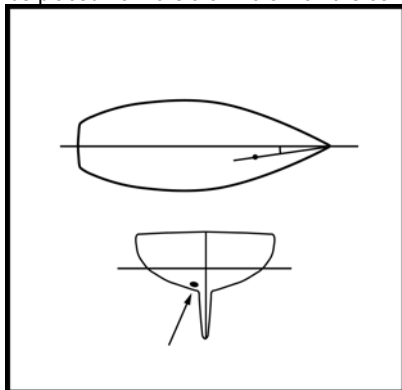

On sailboats with a pronounced "V" in the hull, such as full-keel yachts, it might be favourable to angle the transducer slightly so that it aims at the bow, rather than directly parallel to the centreline.

This will help balanced the passing waterflow measurement from one tack to another.

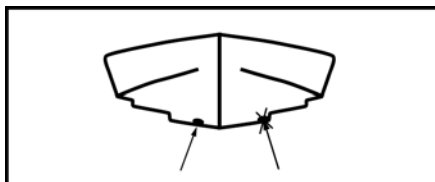

Avoid placing the transducer near the edge of sharp hull chines. Transverse waterflow in these areas can affect the accuracy of measurements.

If you have a questions about the location of the through-hull, contact your builder, yacht dealer, or other owners of similar boats for advice. Always remember to allow for accessibility from the inside of the yacht when determining the final location.

4. INSTALLING THE THROUGH HULL FITTING

1. Use a 43 mm (1 11/16") hole cutter to cut through the hull. (See section 3 for correct location).
2. Apply the polyurethane sealing compound on the outer flange of the through-hull fitting and tighten the nut on the inside by hand.
3. Slide both rubber O-rings on the dummy plug.
4. Generously apply the silicone grease to the exterior of the dummy plug.
5. Install the dummy plug in the through-hull fitting. Use a slow twisting motion and be sure that is properly seated into the fitting.
6. With the dummy plug properly installed in the through –hull fitting, mount the fitting so that the handle is exactly at right angles (90°) to the boats centreline. (For pronounced V-hulls see section 3).
7. When this outer sealant has cured, remove the nut and apply sealant on the inside. Tighten the nut again by hand.
8. Install the wire locking device onto the dummy plug /paddlewheel transducer.

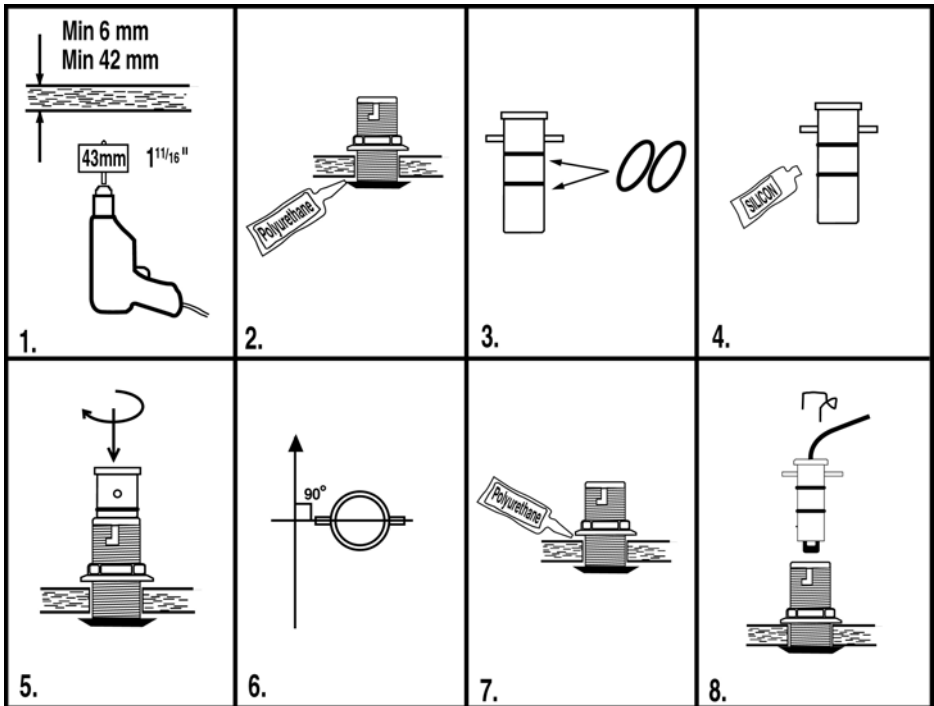

5. CONNECTION TO INSTRUMENT/CONTACTS

The log/temp transducer connects to the Nexus Server or directly to the Nexus Speed Log.

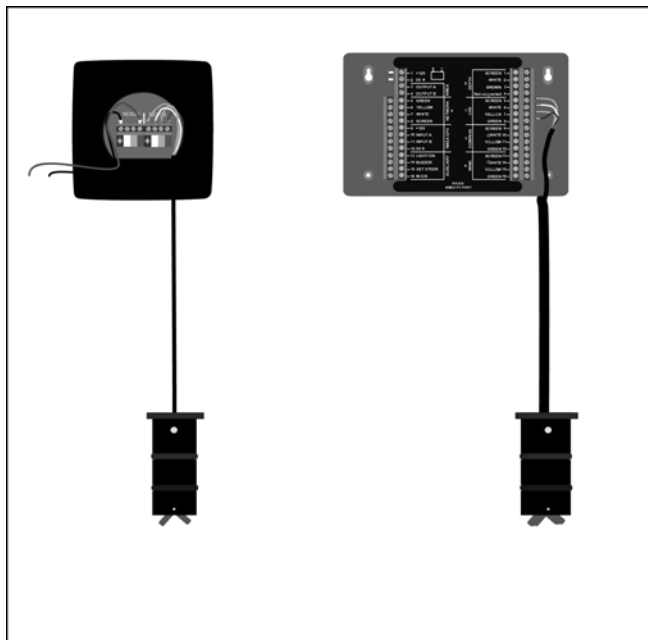

The transducer cable is clearly marked with No 1 and the colours will correspond to input screw terminal on the Server.

If the 8 m transducer cable needs to be cut, use the extra cable protectors supplied. Press the protectors on to each wire with a pair of flat pliers.

6. CALIBRATION

Calibration is carried out in the Multi Control instrument or the speed log instrument (see manual).

7. TECHNICAL DATA

Dimensions:	Through-hull fitting 42 x 86 mm (1 5/8" x 3 3/8") Hull thickness min 6 mm (3/8"), max 42 mm (1 5/8")
Transducer cable:	8 m (26.2 ft)
Power supply:	12V DC (10-16V)
Power consumption:	0,06 W
Accuracy:	± 1%
Speed range	0.2-30 knots (depending on transducer type max. 90 knots)
Temperature range	Operating -10°C to +70°C Storage -35°C to +70°C

8 WARRANTY

GENERAL

All our products are designed and built to comply to the highest class industry standards. If the products are correctly installed, maintained and operated, as described in the installation and operation manual, they will provide long and reliable service. Our international Network of distributors can provide you with the information and assistance you may require virtually anywhere in the world.

Please read through and fill in this warranty card and send it to your national distributor for product registration.

LIMITED WARRANTY

The warranty covers repair of defective parts due to faulty Manufacturing and includes labour when repaired in the country of purchase. The warranty period is stated in the product manual, and commences from the date of purchase. The above warranty is the Manufacturer's only warranty and no other terms, expressed or implied, will apply. The Manufacturer specifically excludes the implied warranty of merchantability and fitness for a particular purpose.

CONDITIONS

- The supplied warranty card and receipt with proof of purchase date, must be shown to validate any warranty claim. Claims are to be made in accordance with the claims procedure outlined below.
- The warranty is non-transferrable and extends only to the original purchaser.
- The warranty does not apply to Products from which serial numbers have been removed, faulty installation or incorrect fusing, to conditions resulting from improper use, external causes, including service or modifications not performed by the Manufacturer or by its national distributors, or operation outside the environmental parameters specified for the Product.
- The Manufacturer will not compensate for consequential damage caused directly or indirectly by the malfunction of its equipment. The Manufacturer is not liable for any personal damage caused as a consequence of using its equipment.
- The Manufacturer, its national distributors or dealers are not liable for charges arising from sea trials, installation surveys or visits to the boat to attend to the equipment, whether under warranty or not. The right is reserved to charge for such services at an appropriate rate.
- The Manufacturer reserves the right to replace any products returned for repair, within the warranty period, with the nearest equivalent, if repair within a reasonable time period should not be possible.
- The terms and conditions of the warranty as described do not affect your statutory rights.

CLAIMS PROCEDURE

Equipment should be returned to the national distributor, or one of its appointed dealers, in the country where it was originally purchased. Valid claims will then be serviced and returned to the sender free of charge.

Alternatively, if the equipment is being used away from the country of purchase, it may be returned to the national distributor, or one of its appointed dealers, in the country where it is being used. In this case valid claims will cover parts only. Labour and return postage will be invoiced to the sender at an appropriate rate.

DISCLAIMER

Common sense must be used at all times when navigating and the Manufacturer's navigation equipment should only be considered as aids to navigation.

The Manufacturers policy of continuous improvement may result in changes to product specification without prior notice.

Copyright ©:
Silva Sweden AB
Kuskvägen 4, 191 62 Sollentuna, Sweden
Tel: +46 -(0) 8 - 623 43 00. Fax: +46 -(0) 8 - 92 76 01
www.silva.se