

INSTRUCTION MANUAL

Simrad HLD350 MK2
Simrad HLD2000 MK2L
Hydraulic Linear Drive

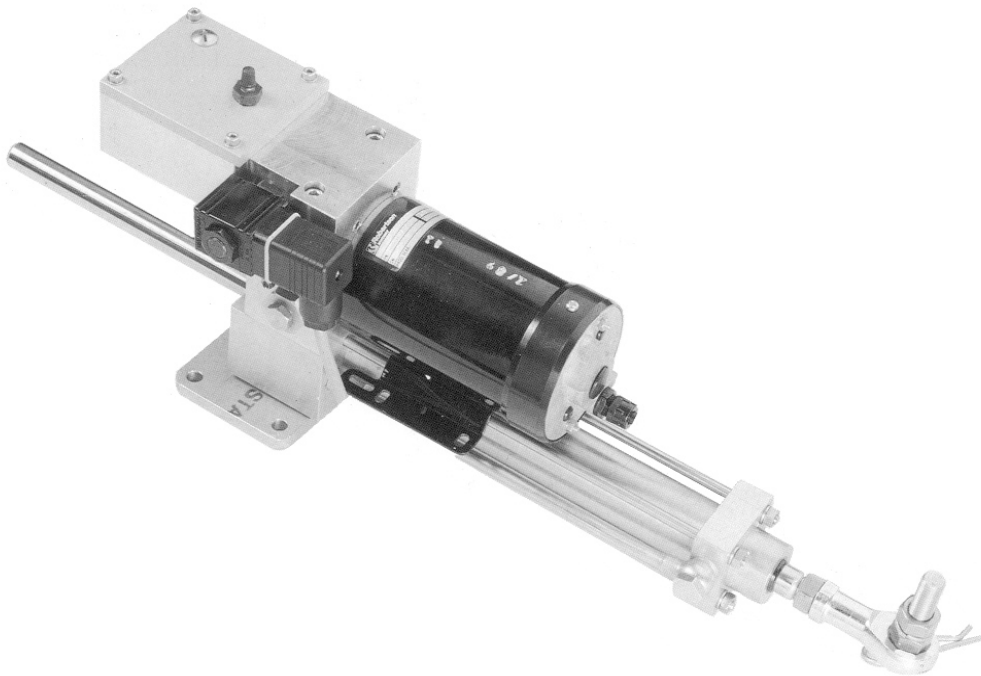

Note!

Simrad AS makes every effort to ensure that the information contained within this document is correct. However, our equipment is continuously being improved and updated, so we cannot assume liability for any errors which may occur.

Warning!

The equipment to which this manual applies must only be used for the purpose for which it was designed. Improper use or maintenance may cause damage to the equipment or injury to personnel. The user must be familiar with the contents of the appropriate manuals before attempting to operate or work on the equipment.

Simrad AS disclaims any responsibility for damage or injury caused by improper installation, use or maintenance of the equipment.

Copyright

© 2005 Simrad AS

The information contained within this document remains the sole property of Simrad AS.

No part of this document may be copied or reproduced in any form or by any means, and the information contained within is not to be communicated to a third party, without the prior written consent of Simrad AS.

Instruction Manual

This manual is intended as a reference guide for correctly installing and maintaining the HLD350 MK2 and HLD2000 MK2 Hydraulic Linear Drives.

Please take time to read this manual to get a thorough understanding of the drive system components and its relationship to a complete autopilot system.

Other documentation material that is provided with your system includes a warranty card. This must be filled out by the authorized dealer that performed the installation and mailed in to activate the warranty.

Instruksjonsmanual

Denne manualen gir veiledning om installasjon og vedlikehold av de hydrauliske drivenhetene HLD350 MK2 og HLD2000 MK2.

For å få en forståelse av drivenhetens virkemåte og funksjon i et autopilotssystem bør manualen leses grundig.

Sammen med ditt system følger et garantikort. Dette må fylles ut av installatør og sendes inn for at garantien skal være gyldig.

Document revisions

Rev	Documentation department		Hardware/Software design		Project/Product Management	
	Date	Sign	Date	Sign	Date	Sign
–	07.97	N.G.	07.97	I.K.	07.97	Th.H.
A	29.04.98	N.G.	29.04.98	I.K.	29.04.98	Th.H.
B	21.09.99	N.G.	21.09.99	I.K.	21.09.99	Th.H.
C	15.11.00	N.G.	16.11.00	I.K.	16.11.00	Th.H.
D	19.02.03	N.G.	19.02.03	I.K.	19.02.03	Th.H.
E	16.02.05	<i>NG</i>			16.02.05	<i>Th. H.</i>

Document history

- Rev. – First edition
- Rev. A New edition including MK2 versions
- Rev. B Added measurement on figure 1. Adjusted figure 5.
- Rev. C New environmentally friendly synthetic hydraulic oil, page 5, 6 and 7. Corrected quantity for Pos.8 Bearing bush on fig. 11 from 1 to 2 and description of P.N. 44165918 on page 23. Distributor list updated.
- Rev. D New motors, type Lemac. Added colour on the o-ring at pos. 6, page 21 to avoid mix up. Minor corrections in text.
- Rev. E Corrected part no. for RPU80 on page 19. Updated with new autopilot computers.

Contents

1	GENERAL	5
2	TECHNICAL SPECIFICATIONS.....	7
2.1	Standard version	7
2.2	Split version.....	8
2.3	Dual cylinder version.....	9
2.4	Comparison chart for HLD MK2 versions	10
3	INSTALLATION	11
3.1	Mechanical installation.....	11
3.2	Electrical connection	12
	AC10/AC20 Autopilot Computer, J300X/J3000X Junction Unit.....	12
	J101A Junction Unit	12
4	CONSTRUCTION AND PRINCIPLE OF OPERATION.....	15
4.1	Tank.....	15
4.2	Reversible Hydraulic Pump.....	16
4.3	Hydraulic Rudder Cylinder	16
5	PARTS LIST.....	19
5.1	Linear drive units and main parts	19
5.2	Tank assembly	20
5.3	Pump assembly	21
5.4	Cylinder assembly	22
6	APPENDIX	24
6.1	Calculation of the force against the rudder.....	24

Innhold

1	GENERELT.....	6
2	TEKNISKE SPESIFIKASJONER.....	7
2.1	Delt versjon.....	8
2.2	Dobbel sylinder versjon.....	9
2.3	Sammenligningstabell for MK2 versjoner	10
3	INSTALLASJON	13
3.1	Mekanisk installasjon	13
3.2	Elektrisk tilkobling	14
	AC10/AC20 autopilotcomputer/J300X/J3000X koblingsenhet	14
	J101A koblingsenhet	14
4	KONSTRUKSJON OG VIRKEMÅTE	17
4.1	Tank	17
4.2	Reverserbar hydraulisk pumpe	17
4.3	Hydraulisk rorsylinder	18
5	PARTS LIST.....	19
5.1	Linear drive units and main parts	19
5.2	Tank assembly	20
5.3	Pump assembly	21
5.4	Cylinder assembly	22
6	TILLEGG	26

1 GENERAL

HLD350 MK2 and HLD2000 MK2 are hydraulic linear drives designed for boats with mechanical steering systems such as wire and cable steering (Edson, Whitlock, Teleflex).

The HLD is a compact, assembled unit, consisting of a reversible hydraulic pump, a balanced hydraulic cylinder, by-pass valve and oil tank.

Because of the direct connection to the rudder, the hydraulic linear drive can be used even if the hand steering should fail. This can be an important safety factor.

The by-pass valve makes it possible to use the helm with little back drive force when the autopilot is switched off.

The HLD350 MK2 and HLD2000 MK2L supersede the previous HLD350 and HLD2000L models. This manual also includes HLD2000 MK2D. This model is based on the same main parts as HLD350 MK2, but uses the HLD2000 MK2LD motor.

The MK2 versions were introduced in April 1998. The cylinder has a slightly increased diameter and requires a modified piston assembly and piston sealing. Otherwise the MK2 versions are identical to the previous HLD350 and HLD2000L. The modified units have got a MK2 added to the type designation on the product label and applies from the following serial numbers and onwards.

The basic specifications are:

Art. no.	Ser. no.	Description
21113303	545H36	HLD350 MK2 (200 mm stroke)
21113311	545H36	HLD350 MK2S (split version)
21113360	4154H69	HLD2000 MK2L (long version, 340 mm stroke)
21113386	4154H610	HLD2000 MK2LS (long, split version)
21113345	3383H68	HLD2000 MK2D (dual cylinder version, 200 mm stroke)
21113402	4154H611	HLD2000 MK2LD (long dual cylinder version)

In this manual HLD is used as a general term for all models. The MK2 designation is added only when specifically required for parts identifications.

All HLD models are supplied with environmentally friendly synthetic hydraulic oil with designation of type Hydralen 32 (viscosity 32 cSt). This oil can without problem substitute/blend with ordinary hydraulic oil with equivalent viscosity (between 15 and 40 cSt)

GENERELT

HLD350 MK2 og HLD2000 MK2 er hydrauliske lineære drivenheter beregnet for båter med mekaniske styresystemer som kabel- og wirestyring (Edson, Whitlock, Teleflex).

Den består av en kompakt sammenbygget enhet som inneholder reverserbar hydraulisk pumpe, balansert hydraulisk sylinder, by-pass ventil og oljetank.

På grunn av den direkte tilkoblingen til roret vil den lineære drivenheten kunne brukes selv om håndstyringen skulle svikte, noe som gir større sikkerhet.

Når autopiloten er avslått eller mister spenningen, vil by-pass ventilen åpne slik at roret kan beveges uhindret ved hjelp av den mekaniske styringen.

HLD350 MK2 og HLD2000 MK2L etterfølger de tidligere modellene HLD350 og HLD2000L. Manualen omhandler også HLD2000 MK2D. Denne modellen baserer seg på samme hoveddeler som HLD350 MK2, men bruker samme motor som HLD2000 MK2LD.

MK2 versjonen ble introdusert i april 1998. Sylindren har en noe større diameter og krever et modifisert stempel og stempelforing. Ellers er MK2 versjonene identiske med HLD350 og HLD2000L. Modifiserte enheter har fått tilføyd MK2 på produktmerkelappen og modifikasjonen er gjort gjeldende fra følgende serienummer:

Art. nr.	Ser. nr.	Beskrivelse
21113303	545H36	HLD350 MK2 (200 mm slaglengde)
21113311	545H36	HLD350 MK2S (delt utgave)
21113360	4154H69	HLD2000 MK2L (lang utgave, 340 mm slaglengde)
21113386	4154H610	HLD2000 MK2LS (lang, delt utgave)
21113345	3383H68	HLD2000 MK2D (dobbel sylinder, 200 mm slaglengde)
21113402	4154H611	HLD2000 MK2LD (lang, dobbel sylinder)

I denne manualen brukes HLD som en generell betegnelse for alle modeller. MK2 er kun brukt når det er behov for å identifisere deler.

Alle HLD modeller leveres med en syntetisk, miljøvennlig hydraulikkolje av typen Hydralen 32 (Viskositet 32 cSt). Denne oljen kan uten problem erstatte/blandes med vanlig hydrolikkolje med tilsvarende viskositet (mellom 15 og 40 cSt).

2 TECHNICAL SPECIFICATIONS

2.1 Standard version

- Motor voltage: 12V DC
- Max. current HLD350/2000L: 10/20A
- Average power consumption: 40 – 60 W
- Peak thrust HLD350/2000L: 350kp / 500kp
- Continuous duty HLD350/2000L: .250kp / 390kp
- Max. speed HLD350/2000L: 10 sec./17 sec. full travel
(Adjustable in the autopilot electronics)
- Stroke: 200mm / 340mm
- Overall length with piston in middle position: 578mm / 858mm
- Dimensions: See fig. 1
- Hydraulic oil: Hydralen 32, High quality environmentally friendly, synthetic hydraulic oil.
- Alternative oil: Norol HM32, Shell Tellus 27, Esso HP15 and Yukong Supervis AW32/X32.)
Viscosity 15-40 cSt at 40°C.

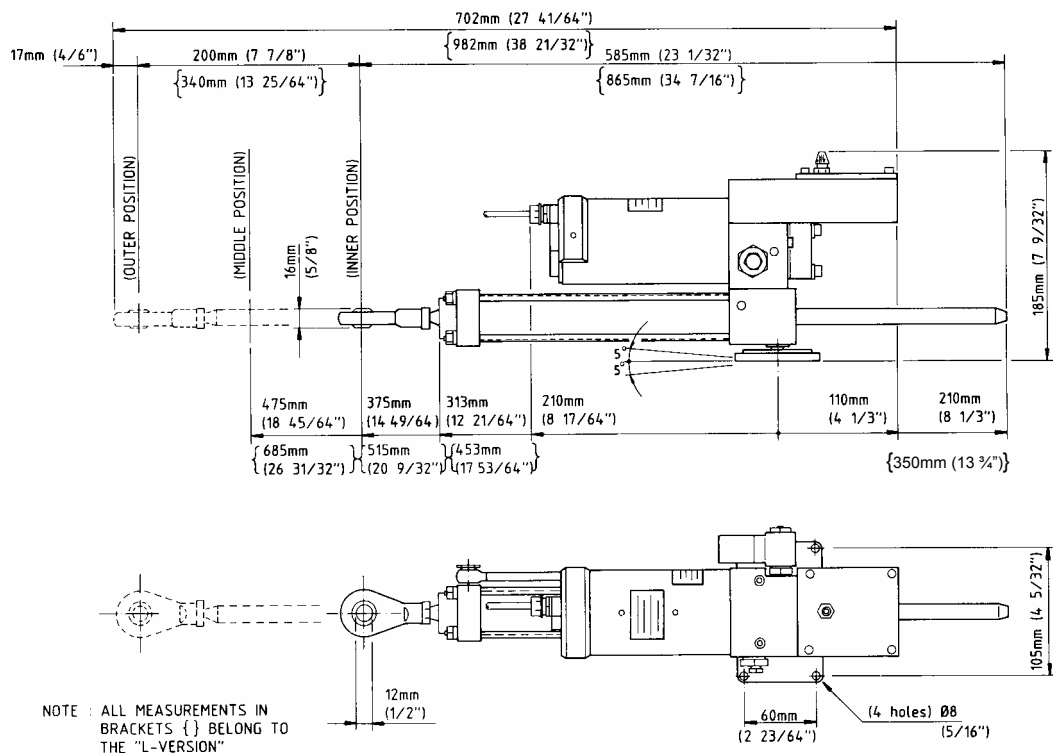

Figure 1 HLD dimensions (shown with Fracmo motor)

2.2 Split version

To obtain good flexibility in the installation of the HLD, a split version is available.

The hydraulic cylinder and the motor/pump-unit are made as separate units with provisions to connect hydraulic hoses between the two. Modifications have been made on the pump housing for this purpose.

The split version is available with standard (200 mm) or long stroke (340 mm) and with hose lengths of 1 m (3 ft).

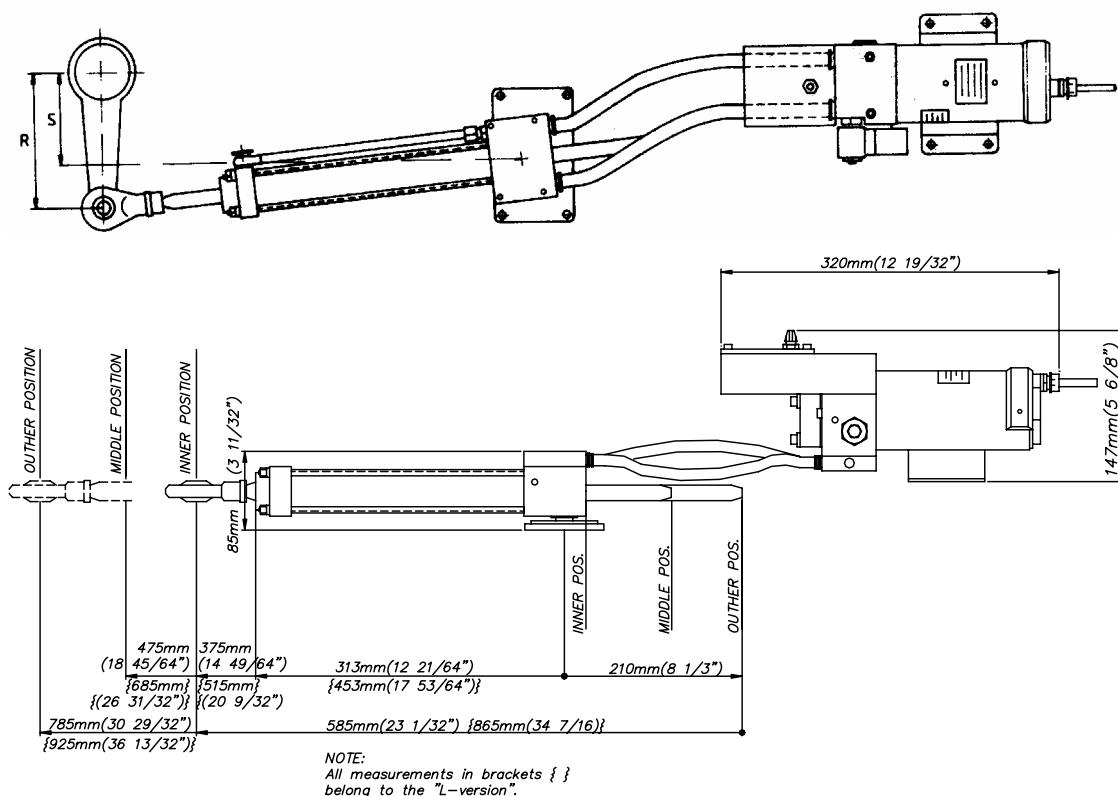

Figure 2 HLD Split version (Shown with Fracmo type motor)

For å oppnå best mulig fleksibilitet ved installasjon er enheten tilgjengelig i delt utgave.

Hydraulisk sylinder og motor/pumpeenhet er laget som separate enheter for sammenkobling ved hjelp av hydraulikk-slanger. I denne forbindelse er det gjort små modifikasjoner på de to enhetene.

Delt utgave kan leveres både med standard slaglengde (200 mm) og med lang slaglengde (340 mm), og med slanger på 1,0 m.

2.3 Dual cylinder version

This model meets the requirement for increased torque without increasing the radial forces on the rudder stock.

It combines a powerful reversible pump (RPU300) with two cylinders having the standard stroke or long stroke. 4 flexible hoses of 1 m (3 ft) connect the pump to the cylinders.

By connecting the cylinders as shown, the radial forces are balanced out, whilst a double torque has been achieved.

The dual cylinder version is for 24V DC operation only.

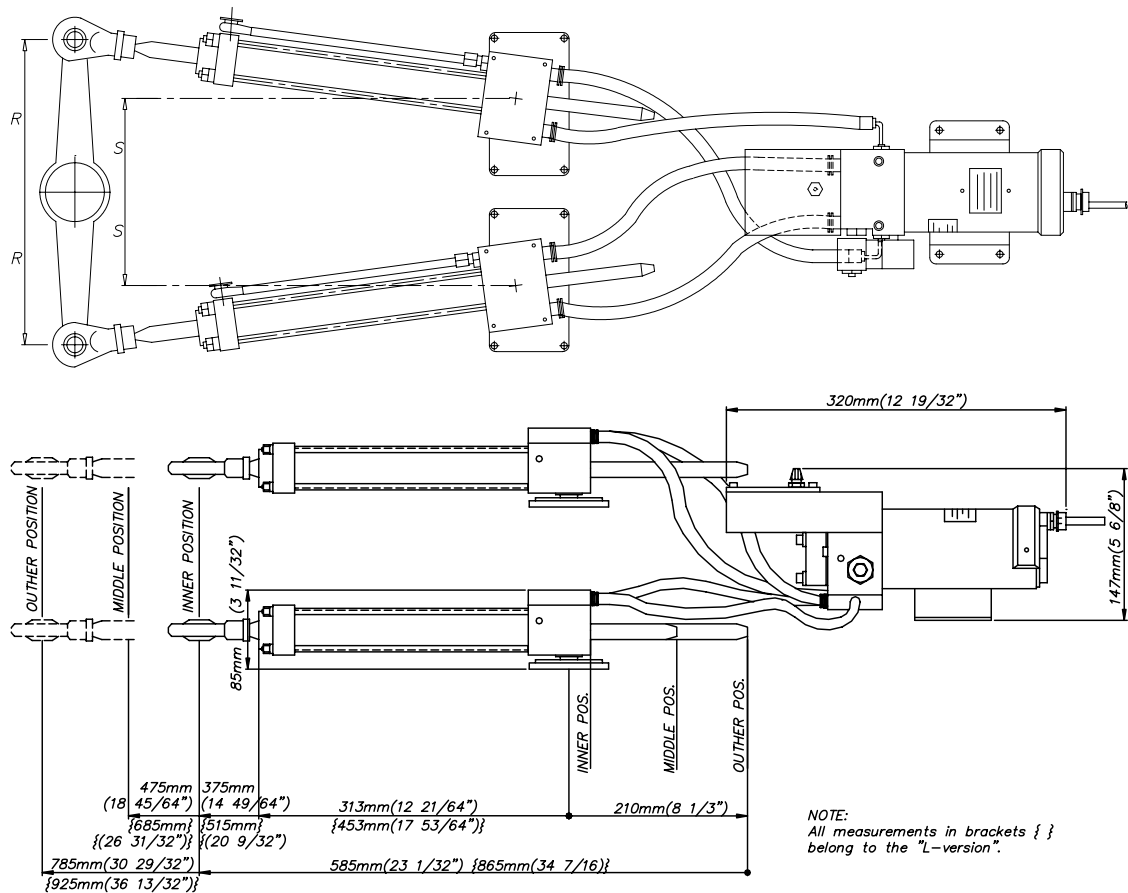

Figure 3 HLD Dual cylinder (Shown with Fracmo type motor)

Denne utgaven med doble sylindere er utviklet for å øke dreiemomentet uten å øke de radielle kreftene som virker på rorstammen.

Den kombinerer en kraftigere reverserbar pumpe (RPU300), med to sylindere med standard slaglengde, eventuelt med lang slaglengde. 4 oljeslanger på 1 m forbinder pumpen med sylindrene. Ved å montere sylindrene som vist på figuren får man balansert de radielle kreftene, samtidig som dobbelt dreiemoment oppnås.

Den doble sylinderversjonen er kun beregnet for 24V DC.

2.4 Comparison chart for HLD MK2 versions

MODEL	MOTOR VOLTS	AUTOPILOT COMPUTER/JUNCTION UNIT	MAX STROKE mm (in.)	PEAK THRUST kg (lb.)	MAX RUDDER TORQUE Nm (lb.in.)	HARD-OVER TIME sec. (30% load)	PWR. CON-SUMP.	TILLER ARM mm (in.)
HLD350 HLD350S	12V	AC10, J3000X	200 (7,9)	350 (770)	610 (5400)	12	3,5-10 A	175 (6,9)
HLD2000L HLD2000LS	12V	AC20, J300X	340 (13,4)	500 (1100)	1460 (12850)	12	5-16 A	298 (11,7)
HLD2000D	24V	AC20, J300X	200 (7,9)	1050 (2310)	1800 (15900)	9	5-16 A	175 (6,9)
HLD2000LD	24V	AC20, J300X	340 (13,4)	1050 (2310)	3180 (28000)	15	5-16 A	298 (11,7)

Steering gear interface: Connects to quadrant or tiller.

1. *The autopilot computer/junction unit steps down the motor voltage when operating from 24V or 32V mains.*
2. *The specified computer/junction unit is necessary to achieve max drive unit capacity.*
3. *Recommended operational thrust or torque is 70% of listed value.*
4. *Typical average power consumption is 40% of listed maximum value.*

Rortilkobling: Kobles til kvadrant eller rorkult.

1. *Autopilotcomputeren/koblingsenheten regulerer ned motorspenningen ved 24V eller 32V nettspenning.*
2. *Spesifisert computer/koblingsenhet er nødvendig for å oppnå maksimal kapasitet fra drivenhet.*
3. *Anbefalt skyvkraft eller moment ved drift er 70% av oppgitt verdi.*
4. *Gjennomsnittlig effektforbruk er typisk 40% av oppgitt maksimumsverdi.*

3 INSTALLATION

Refer to table in section 2.4 to verify that appropriate HLD model is selected for your boat.

If there is any doubt as to whether HLD350/HLD2000L can be installed, this can be clarified by undertaking the calculations shown in the appendix.

3.1 Mechanical installation

Rudder and actuator rod is set to midposition. To obtain maximum and smooth thrust over the actuator's complete stroke, the HLD should be installed in accordance with fig. 6. The distances R and S for different rudder angles are found in the diagram in fig. 4 and 5.

The HLD should be fitted with the enclosed safety connector between actuator and tiller to ensure quick disconnection in emergency situations.

Note ! *Drill and tap the rudder tiller (M12x1.75) to secure the bolt firmly.*

Caution ! *Do never install the unit upside down! (The air valve should be facing upwards.) The HLD must be installed horizontally only. No more than ±5 degrees tilt is allowed at any position, as illustrated on figure 1. The HLD should not act as an end stop for the rudder.*

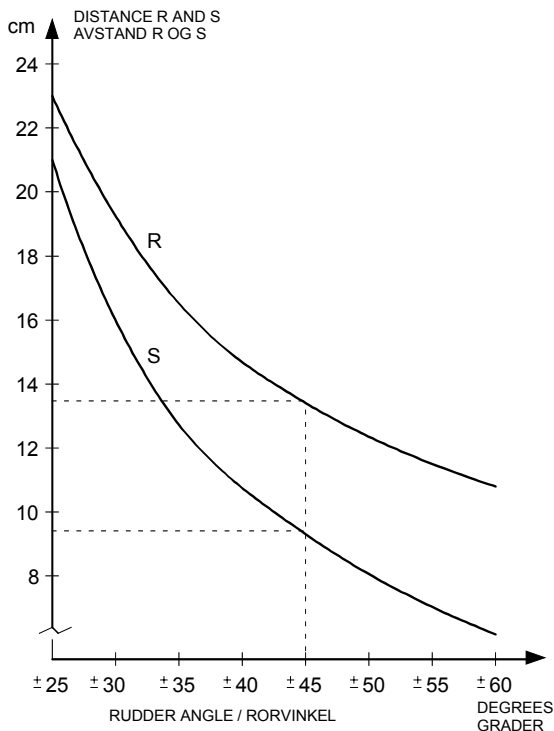

Figure 4 HLD350 Installation diagram

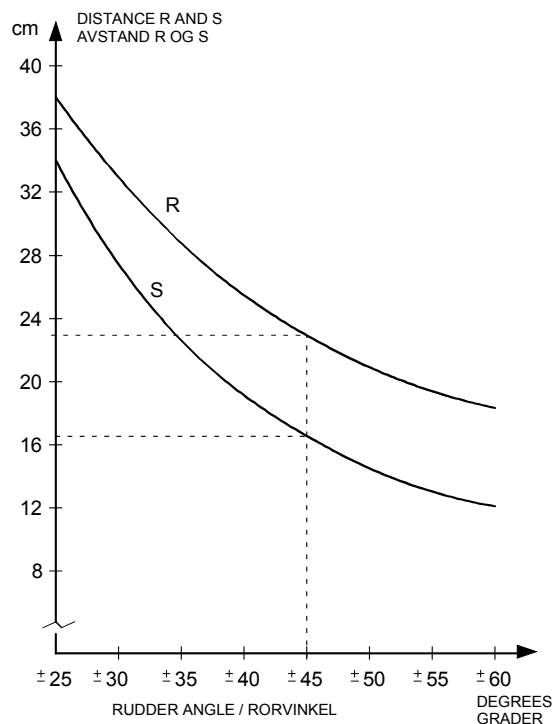

Figure 5 HLD2000L Installation diagram

Remove the valve cap on the tank when the unit is installed.

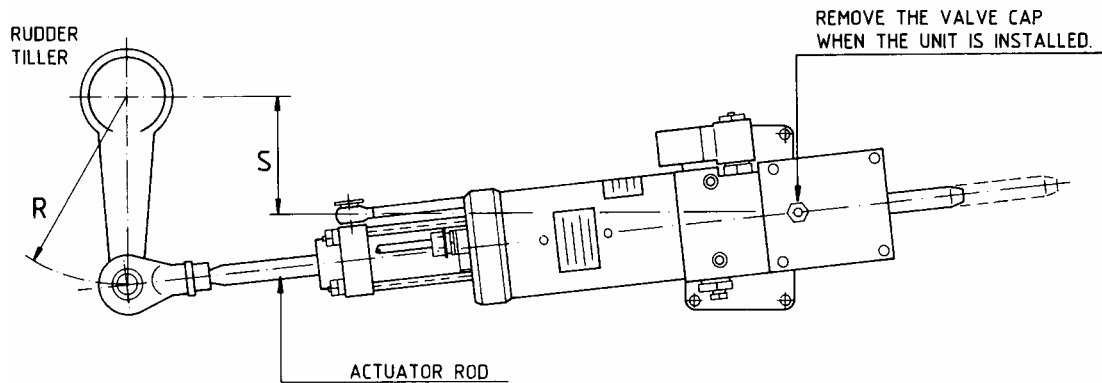

Figure 6 HLD Installation

3.2 Electrical connection

AC10/AC20 Autopilot Computer, J300X/J3000X Junction Unit

The HLD is connected to the autopilot via AC10, AC20, J300X or J3000X according to the following diagram:

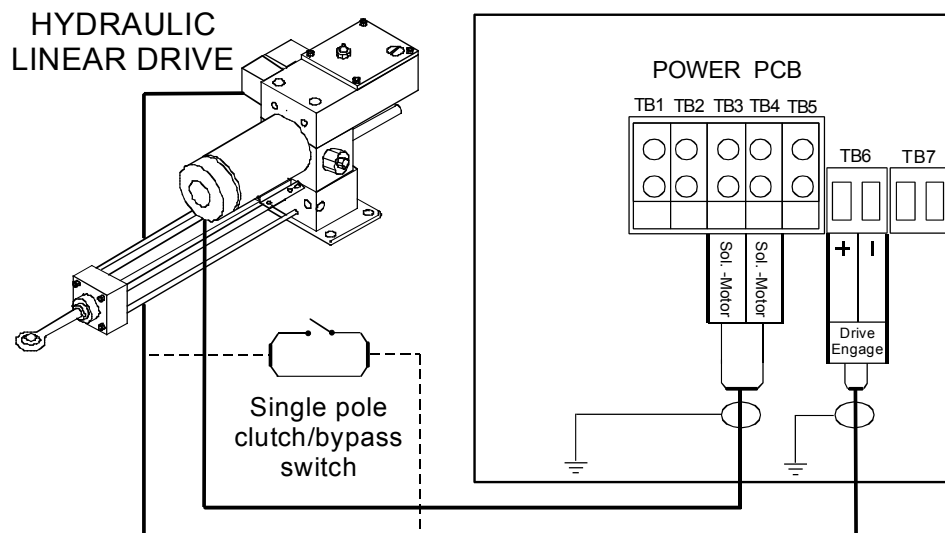

Figure 7 HLD connection to ACXX and J3XX

J101A Junction Unit

The HLD can also be connected to previous models autopilots using the J45A, J101A or J1000 Junction units. The Junction Unit controls the current to the motor and the bypass valve. The Junction Unit also has built-in speed regulation of the HLD, which allows rudder speed

adjustment (i.e. the steering performance of the boat when autopilot steering) after installation of the system.

Note that for the HLD350 (not the HLD2000L) the trim potentiometer RV1 in J1000/J101A/J45A should be adjusted to approx. 2/3 of full C.W. position.

The J1000/J101A/J45A also has a built-in current limiter to prevent overload of the motor (Max. current is 20A).

Motor/bypass connection

The bypass valve is connected to terminal 13 and 14 in J45A/J101A/J1000, and is polarity independent.

The motor is connected to terminal A and B in J45A/J101A/J1000. Interchange of A and B will change the direction of rotation.

Cable for the motor supply voltage from the ship mains must be at least $2 \times 4 \text{mm}^2$ (AWG10), and fused according to the table enclosed with the J101A/J1000.

INSTALLASJON

Kontroller mot tabellen under seksjon 2.4 at riktig HLD model er valgt.

Er det tvil om hvorvidt HLD350 eller HLD2000L skal velges, kan dette klargjøres ut fra beregningene som er vist i tillegget bak i manualen.

Mekanisk installasjon

Plasser stempelstang og ror i midtstilling. HLD monteres slik fig. 6 viser for å få maksimal skyvkraft langs hele stempelstangens vandring. Avstandene R og S ved de forskjellige rorvinkler finnes i diagram fig. 4 og 5.

HLD er utstyrt med hurtigkopling mellom stempelstang og rorkult som tillater hurtig frakobling i nødssituasjoner.

Bruk M12x1,75 gjengetapp og gjeng opp i rorkult.

HLD må aldri monteres opp ned! (Lufteventil på tank skal peke oppover). Enheten må monteres horisontalt, og slik at avviket fra horisontalplanet aldri overstiger ± 5 grader, slik som illustrert på fig. 1. HLD må ikke monteres slik at den fungerer som endestopp for roret.

Husk å skru av ventilhetten på tanken etter at enheten er montert.

Elektrisk tilkobling

AC10/AC20 autopilotcomputer,

J300X/J3000X koblingsenhet

HLD kobles til autopiloten via AC10, AC20, J300X eller J3000X i henhold til fig. 7.

J101A koblingsenhet

HLD kan også kobles til tidligere autopilotmodeller som bruker J101A eller J1000 koblingsenheter. Koblingsenhetene kontrollerer strømmen til motoren og by-pass ventilen. Koblingsenheten har også innebygget hastighetsregulering av HLD, noe som gir anledning til å justere rorhastighet (og dermed båtens styreegenskaper med autopilot) etter at systemet er installert.

Ved bruk av HLD350 (gjelder ikke HLD2000L) bør trimme-potensiometer RV1 i J45A/J101A/J1000settes til ca. 2/3 av fullt område.

I J45A/J101A/J1000er det også innebygget en strømbegrenser som hindrer overbelastning av motor (maks. strøm er 20A).

Kobling av motor/bypassventil:

Bypassventil kobles til terminal 13 og 14 i J45A/J101A/J1000 og er polaritetsuavhengig.

Motoren kobles til terminal A og B i J45A/J101A/J1000. Ombytting av A og B vil snu motorens dreieretning.

Kabel for motorspenning fra båtens fordelingskap må være minst $2 \times 4 \text{mm}^2$ og sikret i.h.h.t. tabell vedlagt i J45A/J101A/J1000.

4 CONSTRUCTION AND PRINCIPLE OF OPERATION

The HLD is delivered completely assembled with tank, reversible hydraulic pump and a balanced hydraulic cylinder. The HLD is therefore a completely closed system.

4.1 Tank

The tank is machined out of solid aluminium and all necessary oil ways are drilled out.

A bypass valve is mounted in the tank, to allow the mechanical steering system to be used, when the autopilot is not in operation.

The bypass valve is a standard ON/OFF solenoid valve, normally open.

When the autopilot is in STBY mode, the solenoid valve will be in open position.

When AUTO or NAV mode is selected, the solenoid valve will be in closed position.

The solenoid valve opens immediately when the autopilot is switched off, and handsteering is allowed.

Previous versions

An early version of HLD350 and HLD350S did not have check valves. The following serial no. codes can identify it: H30 (HLD350) and H31 (HLD350S).

The principle of operation was similar to that of HLD2000L. The (suction) valves, however, operated as combined suction and (non-return) check valves controlled by internal pressure and direction of oil flow. The resulting effect was a smoother check valve operation as

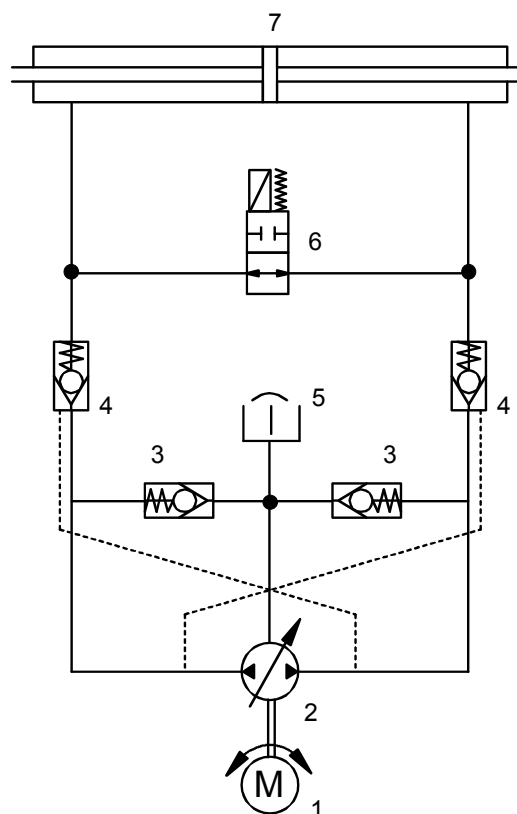

Functional diagram

1. Electrical motor (Elektromotor)
2. Gear pump (Tannhjulspumpe)
3. Suction valve (Innsugingsventil)
4. Check valve (Tilbakeslagsventil)
5. Oil tank (Oljetank)
6. By-pass valve (By-pass ventil)
7. Hydraulic actuator (Hydraulisk sylinder)

compared to the ones with separate check valves. It should be observed however, that this version does not have the extra protection against internal leakage (bypass) as the models with separate check valves.

4.2 Reversible Hydraulic Pump

The pump consists of valve block, reversible gear pump, pressure operated check (non-return) valves, electric permanent magnet motor, suction valves and slide.

The pump is reversible, i.e. the motor changes direction of rotation and the gear pump delivers oil to that side of the rudder cylinder dictated by the signal from the autopilot. When the motor is running, the pressurised (or delivery) side will hold both check valves open, using direct oil pressure upon the valve on the delivery side. This oil pressure is also used to push a slide to open the valve on the suction side.

When the motor stops, the spring in the check valve on the suction side returns the slide to the neutral position. Both check valves are now closed and the rudder cylinder locked. Both sides of the gear pump are able to suck oil from the tank through the suction valves.

4.3 Hydraulic Rudder Cylinder

The rudder cylinder consists of the cylinder itself, actuator, actuator rod, ball joint and base plate.

The actuator rod runs through the cylinder. The actuator area is identical on both sides, and this balances the cylinder.

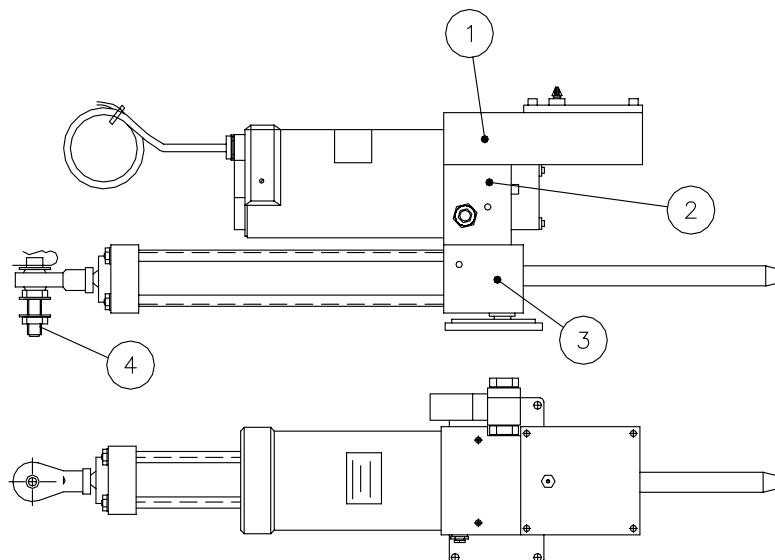

*Figure 8 HLD Assembly drawing (N3-111832)
(Shown with Fracmo type motor)*

KONSTRUKSJON OG VIRKEMÅTE

HLD leveres komplett sammenbygget med tank, reverserbar hydraulisk pumpe og balansert hydraulisk sylinder. Den arbeider dermed i et lukket system.

Tank

Tanken er frest ut av massiv aluminium og nødvendige oljeløp er utboret.

I tanken er det montert en bypass-ventil for at det mekaniske styresystemet skal kunne brukes når autopiloten ikke er i bruk.

Bypass-ventilen er en standard Av/På magnetventil som normalt er åpen.

Magnetventilen er åpen når autopiloten er i STBY og lukket når autopiloten er i AUTO eller NAV. Ventilen åpner umiddelbart når autopiloten slås av slik at håndstyring kan benyttes.

Tidligere versjoner

En tidligere versjon av HLD350 og HLD350S har ikke tilbakeslagsventil. Denne versjonen identifiseres med følgende serie nr. kode: H30 (HLD350) og H31 (HLD350S).

Betjeningsprinsippet var tilsvarende som for HLD2000L. Innsugnings-ventilene fungerte imidlertid som kombinerte innsugings- og tilbakeslagsventiler kontrollert av det interne trykket og retningen av oljestrømmen. Effekten av dette var en jevnere sperrefunksjon sammenlignet med enheter med egen tilbakeslagsventil. Denne versjonen gir imidlertid ikke den ekstra beskyttelse mot intern lekkasje som den med egen tilbakeslagsventil gir.

Reverserbar hydraulisk pumpe

Pumpen består av ventilblokk, pumpeenhet, motor med permanente magneter, tilbakeslagsventiler og sleide.

Pumpen er reverserbar, dvs. at motoren kan endre dreieretning og tannhjulspumpen vil levere oljen enten til den ene eller andre enden av rorsylindren, avhengig av signalene fra autopiloten.

Når motoren går, vil pumpens trykkside holde begge de trykkstyrte tilbakeslagsventilene åpne. Tilbakeslagsventilen på trykksiden åpnes direkte av oljetrykket, mens den på sugesiden blir åpnet av en sleide som skyves over av oljetrykket på trykksiden.

Når signalet fra piloten opphører, vil fjæren i tilbakeslagsventilen på sugesiden trykke sleiden tilbake til nøytralstilling. Begge tilbakeslagsventilene vil da være lukket. Den hydrauliske sylindren

er dermed låst. Begge sider av tannhjulpumpen kan suge fra tank via innsugningsventiler.

Hydraulisk rorsylinder



Rorsylinderen består av cylinderrør, stempelstang med stempel, endestykke og fot.

Stempelstangen er gjennomgående. Stempelarealet er likt på begge sider, og cylinderen er dermed balansert.

5 PARTS LIST

5.1 Linear drive units and main parts

Refer to Figure 8.

Pos.	Part no.	Description
	21113303	HLD350 MK2 Hydraulic linear drive complete, stroke 200 mm
	21113311	HLD350 MK2S Hydraulic linear drive complete, stroke 200 mm, split version
	21113360	HLD2000 MK2L Hydraulic linear drive complete, stroke 340 mm
	21113386	HLD2000 MK2LS Hydraulic linear drive complete, stroke 340 mm, split version
	21113345	HLD2000 MK2D Hydraulic linear drive complete, stroke 200 mm, dual cylinders
	21113402	HLD2000 MK2LD Hydraulic linear drive complete, stroke 340 mm, dual cylinders
1	21112826	Tank assembly 12V (standard) Option: 24V (voltage to be specified)
2	21112859	Pump assembly complete with motor (12V)
		Motor parts (LEMAC)
	44170199	RPU80 Lemac motor (HLD350/HLD350S) (Substitutes RPU80 Fracmo motor)
	44177525	RPU160 Lemac motor (HLD2000L/HLD2000LS) (Substitutes RPU100 Fracmo motor)
	44169845	Brush for RPU80/160 Lemac motor, C8386 9x6x18,2mm
	44170132	Brush cap for RPU80/160 Lemac motor
	44169993	RPU300 Lemac motor, 24V (HLD2000D/HLD2000LD) (Substitutes RPU300 Fracmo motor, 24V)
	44170116	Brush for RPU300 Lemac motor, short type, 12,7x7,94x12mm
	44170108	Brush for RPU300 Lemac motor, long type, 12,7x7,94x19mm
	44170124	Brush cap for RPU300 Lemac motor
		Parts for Fracmo motors:
	44163228	Brush cap RPU80/160 Fracmo – Type I
	44163236	Brush cap RPU80/160 Fracmo – Type II

	44161933	Brushes for RPU80 motor
	44133056	Brushes type CB156 for RPU100 Fracmo (spade connector)
	44136356	Brushes type CB174 for RPU100 Fracmo (male/female connector)
3	21113287	HLD350/2000 MK2 (D) Hydraulic cylinder ass'y
	21113279	HLD2000 MK2L Hydraulic cylinder ass'y
4	21109228	Emergency release pin complete

5.2 Tank assembly

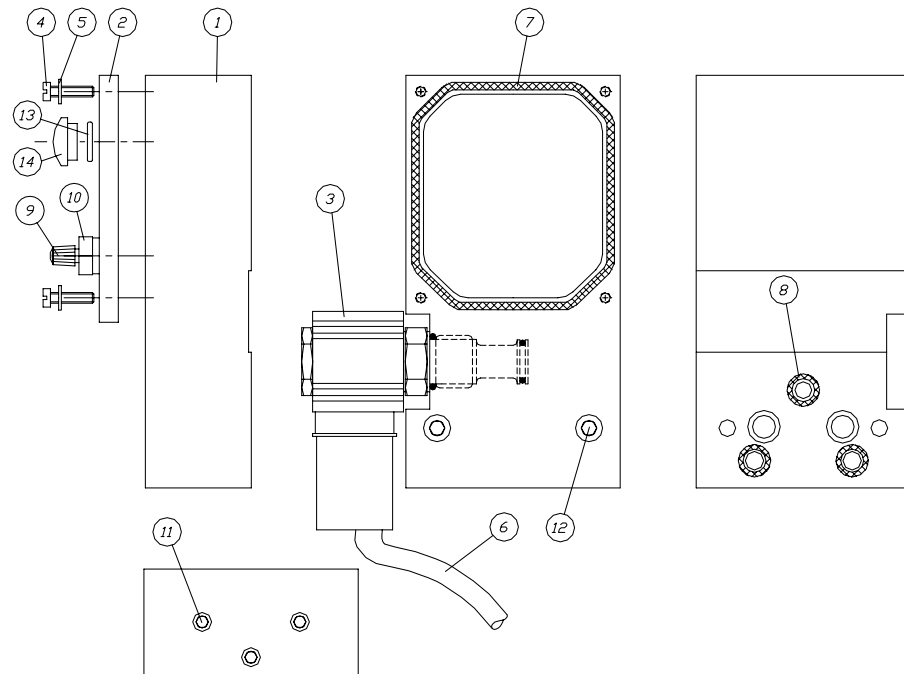

Figure 9 HLD Tank assembly (N3-111282C)

Pos.	Qty	Part no.	Description
1	1	21112891	Tank
2	1	21112800	Cover for tank
3	1	44156537	Solenoid valve 12V, complete
		44157634	Coil 12V
		44156594	Solenoid valve 24V, complete
		44157626	Coil 24V
4	4	44150555	Screw sock. Head M4x16
5	4	44150274	Washer M4
6	1	21112834	Cable
7	1	44154672	O-ring Ø85,34x1,78

8	5	44154839	O-ring 8,73x12,29x1,78
9	1	44153773	Valve with cap
10	1	44154128	Nipple Ø6 R 1/4
11	3	44154565	Set screw M8x8
12	2	44154458	Screw sock. head M6x40
13	1	44157790	O-ring Ø10,82x1,78
14	1	44157774	Blind plug PG7
15	1	44157865	O-ring Ø14,00x2,00
16	1	44157873	O-ring Ø16,36x2,21

5.3 Pump assembly

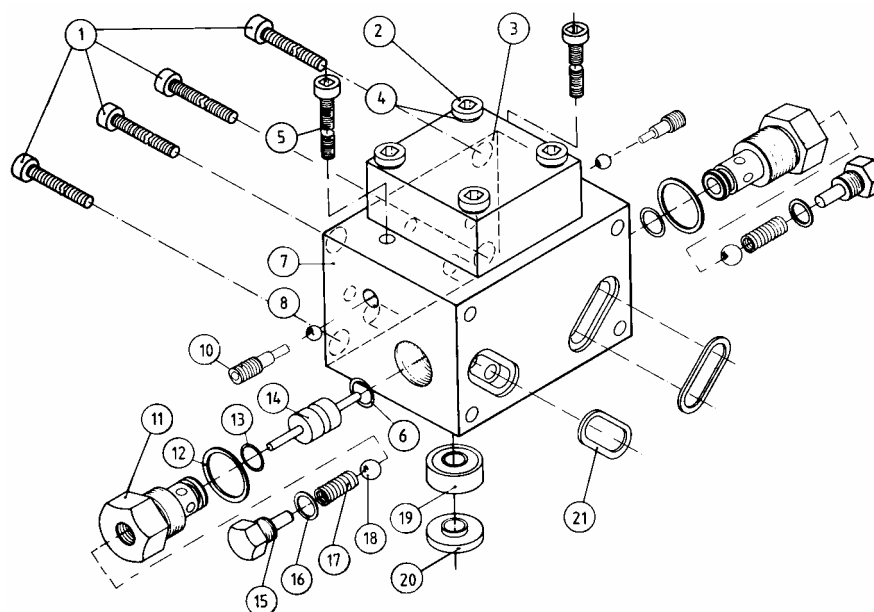

Figure 10 Pump assembly

Pos.	Qty.	Part no.	Description
1	4	44149912	Screw sock. Head M5x60
2	4	44152775	Screw sock. Head M6x35
3	1	21101191	Pump cover
4	4	44150050	Split washer M6
5	2	44149912	Screw sock. Head M5x60
6	1	44154656	O-ring Ø9,25x1,78 silicon, red
7	1	21109038	Valve block
8	2	44118552	Steel ball Ø6,35
10	2	21112933	Grub. screw sock. head M8
11	2	21100276	Valve housing

12	2	44149706	Copper Washer Ø20/24x1,5
13	2	44149649	O-ring 9,25x1,78 Nitrile
14	1	21100268	Slide
15	2	21100292	Plug
16	2	44148146	Copper washer Ø10,2x14x1
17	2	21100193	Spring
18	2	44149656	Steel ball Ø8
19	1	44149722	Oil seal 8x22x7
20	1	21100185	Support ring
21	2	44154888	O-ring Ø18,77x1,78

5.4 Cylinder assembly

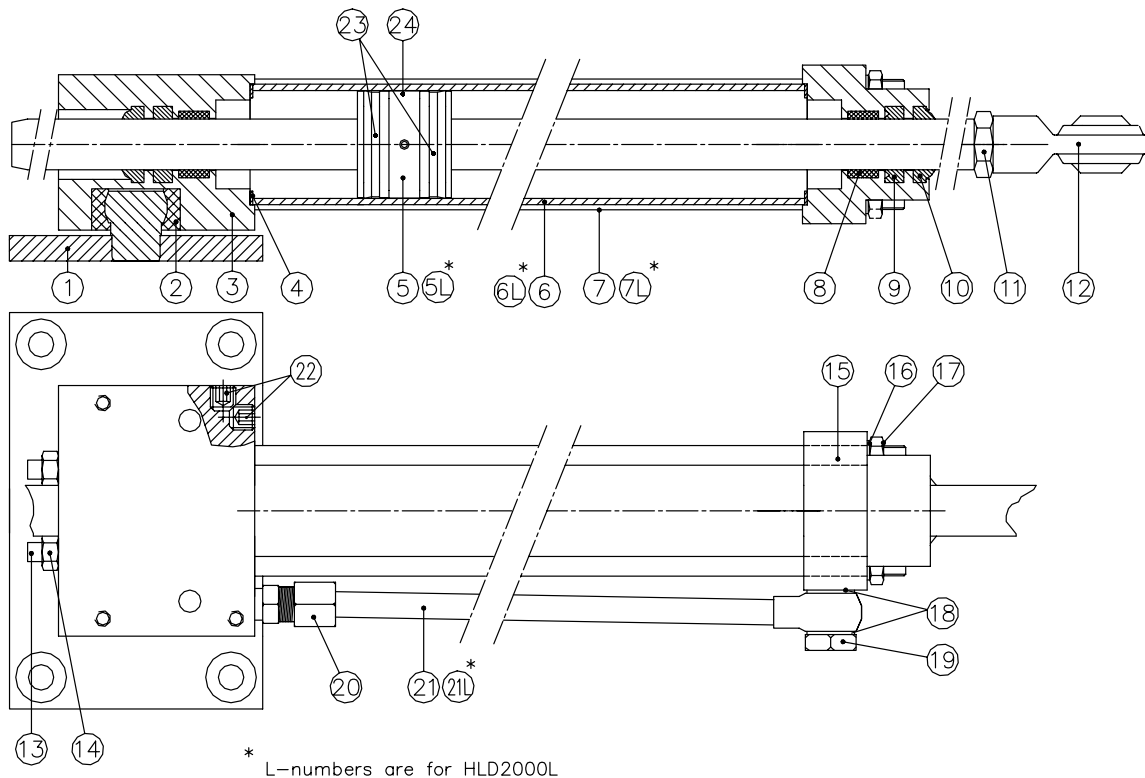

Figure 11 Cylinder assembly (N3-111284A)

Pos.	Qty.	Part no.	Description
1	1	21215991	Base plate complete
2	1	21219019	Plastic bearing
3	1	21112768	Back end piece
4	2	21219027	Gasket
5	1	21112867	HLD350 Piston complete

5	1	21113063	HLD350 MK2 Piston complete
5L	1	21113253	HLD2000L Piston complete
5L	1	21113071	HLD2000 MK2L Piston complete
6	1	21112974	Cylinder
6L	1	21112982	Cylinder
7	4	21109111	Studs
7L	4	21112024	Studs
8	2	21112917	Bearing bush
9	2	44156578	Oil seal 16x24x5,5
10	2	44156586	Cleaner Ø16x24x7,4
11	1	44140076	Nut M12
12	1	21113295	Ball joint Ø12xM12
13	2	44150035	Set screw M6x6
14	2	44150043	Nut M6
15	1	21112784	End piece
16	4	44150050	Washer M6
17	4	44150068	Nut M6
18	2	44148039	Copper washer 12x16x1,5
19	1	44165892	Hollow screw M12x1,5 single
20	1	44165900	Clamping ring coupling M10x1x8
21	1	21113030	Pipe with banjo coupling
21L	1	21113055	Pipe with banjo coupling
22	2	44154565	Set screw M8x8
23	2	44165918	Nut ring UM 35-25-5
24	1	21113048	Bearing bush

6 APPENDIX

6.1 Calculation of the force against the rudder

1. When the rudder torque is known.

The rudder torque is usually obtained from the boat builder.

To find the force against the rudder, the length of the rudder tiller must first be known. This can be calculated from the formula:

$$R = \frac{l}{\sin a} \text{ (m)}$$

where R = rudder tiller length

a = one half of the rudder angle

l = one half of the stroke length(0.10m/0.17m)

The force F against the rudder is calculated from the formula:

$$F_r = \frac{M}{R} \text{ (kp)}$$

where

F_r = rudder force

M = rudder torque (kpm)

R = rudder tiller (m)

Use the table on page 10 to find the appropriate drive unit. If the boat is going on cruises for several days, it is recommended to select a unit where F_r not exceeds 70% of listed max. thrust.

2. When the rudder torque is unknown.

First the helm torque must be found. The following measurements/calculations must be carried out:

At full speed ahead and the rudder hard over, find the maximum force F required to turn the helm by using a spring balance.

Measure the radius r of the helm. The helm torque is calculated from the formula:

$$M_r = F \times r \text{ (kpm)}$$

M_r = helm torque

F = helm force (kp)

r = helm radius (m)

To convert the helm torque to rudder torque the turn-over ratio must first be found:

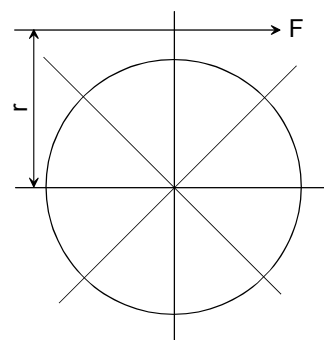

$$I = \frac{360T}{2a}$$

i = turn-over ratio

T = numbers of turn (hard over-hard over)

a = one half of the rudder angle

Now we can find the rudder torque from the formula:

$$M = M_r \times i \text{ (kpm)}$$

M = rudder torque

M_r = helm torque (kpm)

i = turn-over ratio

When the rudder torque is known, use the same procedure as for point 1 to find the rudder force F.

Example:

The helm force is measured to 6.5kp and the radius to 0.3m. Number of turns from hard over to hard over is 3 and the total rudder angle is 90 degrees.

Put into the formula: $M_r = 6.5kp \times 0.30m = \mathbf{1.95kpm}$

$$\text{Turn-over ratio: } i = \frac{360 \times 3}{2 \times 45} = \mathbf{12}$$

$$\text{Rudder torque: } M = 1.95kpm \times 12 = \mathbf{23.4kpm}$$

$$\text{Length of rudder tiller } R = \frac{0,10}{\sin 45} = \mathbf{0.14m}$$

$$\text{(HLD2000L: } R = \frac{0,17}{\sin 45} = \mathbf{0.24m})$$

The length of rudder tiller should be reduced to 0.135m (0.23m), to avoid the HLD acting as an endstop for the rudder.

$$\text{Rudder force } F_r = \frac{23,4kpm}{0,135m} = \mathbf{173kp}$$

$$\text{(HLD2000L: } F_r = \frac{23,4kpm}{0,23m} = \mathbf{102kp})$$

As 173kp (102kp) is less than 350kp the HLD350 MK2 can be installed.

TILLEGG

Beregning av kraften som virker på roret

1. Når rormomentet er kjent

Rormomentet kan i de fleste tilfeller opplyses av båtprodusenten.

For å finne kraften på roret i kp, må vi først vite hvor lang rorkulten er. Denne finnes ved hjelp av formelen:

$$R = \frac{l}{\sin a} \text{ (m)}$$

der R = rorkult

a = halve rorvinkelen

l = halve slaglengden (0.10m/0.17m)

Kraften F_r på roret finnes nå ved hjelp av formelen:

$$F_r = \frac{M}{R} \text{ (kp)}$$

der

F_r = kraften som virker på roret

M = rormoment (kpm)

R = rorkult (m)

Bruk tabellen på side 10 for å finne den aktuelle drivenheten. Det anbefales at F_r ikke overstiger 70% av den oppgitte skyvkraft dersom båten skal seile kontinuerlig i flere døgn.

2. Når rormomentet er ukjent

Først må vi finne rattmomentet. Følgende målinger/beregninger utføres:

Fest en fjærvekt til rattet og mål den maksimale kraften F som skal til for å dreie rattet når båten går med full fart og med roret nesten i borde. Mål radien r på rattet. Rattmoment regnes ut etter formelen:

$$M_r = F \times r \text{ (kpm)}$$

M_r = rattmoment

F = kraft på rattet (kp)

r = radien på rattet (m)

For å regne om rattmoment til rormoment må først omsetningsforholdet finnes:

$$I = \frac{360T}{2a}$$

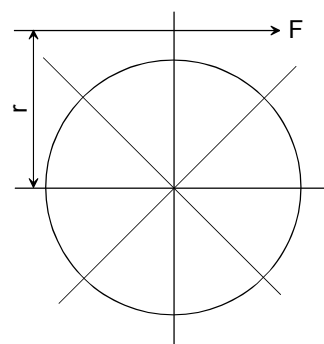

i = omsetningsforhold
 T = antall rattørn (borde til borde)
 a = halve rorvinkel

Nå finner vi rormomentet med formelen:

$$M = M_r \times i \text{ (kpm)}$$

M = rormoment

M_r = rattmoment (kpm)

i = omsetningsforhold

Når rormomentet nå er kjent brukes samme fremgangsmåte som under punkt 1.

Eksempel:

Kraften F på rattet måles til 6.5kp og radien til 0.3m. Antall tørn fra borde til borde er 3 og rorvinkelen er totalt 90 grader.

Sett inn i formelen: $M_r = 6.5kp \times 0.30m = \mathbf{1.95kpm}$

$$\text{Omsetningsforholdet er: } i = \frac{360 \times 3}{2 \times 45} = \mathbf{12}$$

$$\text{Rormoment: } M = 1.95kpm \times 12 = \mathbf{23.4kpm}$$

$$\text{Lengde av rorkult } R = \frac{0,10}{\sin 45} = \mathbf{0.14m}$$

$$\text{(HLD2000L: } R = \frac{0,17}{\sin 45} = \mathbf{0.24m})$$

Lengden av rorkult bør reduseres til 0,135 m (0,23 m) slik at HLD ikke virker som endestopp for roret.

$$\text{Kraften på roret } F_r = \frac{23,4kpm}{0,135m} = \mathbf{173kp}$$

$$\text{(HLD2000L: } F_r = \frac{23,4kpm}{0,23m} = \mathbf{102kp})$$

Da 173kp (102kp) er mindre enn 350kp kan HLD350 MK2 installeres.

SALES AND SERVICE WORLDWIDE (03.01.05)

EUROPE

AUSTRIA

(Recreational)
Allroundmarin Marine GmbH
Griesfeldstrasse 1
2351 Wiener Neudorf
Tel.: +43 2236 646 760
Fax: +43 2236 646 7676
www.allroundmarin.com

BENELUX

Simrad BV
P. O. Box 587
3200 AM Spijkenisse
Tel.: +31 181 600234
Fax: +31 181 626688
www.bennexholland.nl

CROATIA

Almar d.o.o.
Porec - Kamenarija 12
52452 Funtana
Tel.: +385 52 445 005
Fax: +385 52 445 276

CYPRUS

Regis Marine Electr. Ltd.
163 Leontiou A Street
PO Box 56320
3360 Limassol
Tel.: +357 25 366977
Fax: +357 25 347209

DENMARK

Simrad AS (DK)
Naverland 22
2600 Glostrup
Tel.: +45 43 44 49 00
Fax: +45 43 44 48 99
www.simrad.dk

ESTONIA

Balti Merekaatrid
Marine Department
Pärnu Mnt. 232
11314 Tallinn
Tel.: +372 67 10 075
Fax: +372 67 10 099

FINLAND

AT - Marine OY
Mesikukantie 16
01300 Vantaa
Tel.: +358 9 5494 2600
Fax: +358 9 5494 2700
www.atmarine.fi

(Recreational)

Oy Maritim Ab
P.O. Box 46
00211 Helsinki
Tel.: +358 9 681 631
Fax: +358 9 692 7917
www.maritim.fi

FRANCE

Simrad S.A.
Parc d'Activités Ragon
23 Avenue Pasteur
44 119 Treillieres
Tel.: +33 2 28 01 23 01
Fax: +33 2 28 01 21 43
www.simrad.fr

GERMANY

Main office with administration:
Simrad GmbH
Lollfuss 43-45
D-24837 Schleswig
Tel.: +49 4621 96130
Fax: +49 4621 96139
www.simrad.de

Delivery adress and German Stock:

Simrad GmbH
Dithmarscher Straße 16
D-26723 Emden
Tel.: +49 4921 9686 0
Fax: +49 4921 9686 77

GREAT BRITAIN

Simrad Ltd
Unit 810, Fareham Reach
166 Fareham Road, Gosport
Hampshire PO13 0FW
Tel.: +44 1329 245100
Fax: +44 1329 245111
www.simrad.com

GREECE

Aegean Electronics S.A.
1-3, Akti Miaouli Str.
185 35 Piraeus
Tel.: +302 10 413 7269
Fax: +302 10 413 7270

ICELAND

Fridrik A. Jonsson HF
Eyjarlod 7
P.O.Box 362
121 Reykjavik
Tel.: +354 552 2111
Fax: +354 552 2115

ITALY

Simrad Srl.
Viale Odone Belluzzi 57
00128 Rome
Tel.: +39 06 5078 1022
Fax: +39 06 5078 1024
www.simrad.it

MALTA

Medcomms Ltd.
4 Msida Rd.
Gzira GZR03
Tel.: +356 21 335521
Fax: +356 21 310820

NORWAY

Simrad Marine AS
Joh. Berentsensvei 109
P.O. Box 53, Laksevåg
5847 Bergen
Tel.: +47 55 94 10 00
Fax: +47 55 94 10 05
www.simrad.no

POLAND

Escort Ltd. Electronics Syst.
Ul. Energetyków 9
70-656 Szczecin
Tel.: +48 91 462 4379
Fax: +48 91 462 4408
www.escort.com.pl

PORTUGAL

Nautel - Sistemas Electronics Lda.
Rua Fernão Mendes Pinto, 46
1400-146 Lisboa
Tel.: +351 21 300 70 30
Fax: +351 21 300 70 39
www.nautel.pt

ROMANIA

Intersat Radio srl, CEO
Eden Kessler
Str. Vasile Marcovici nr. 7
9100130 Constanta
Tel.: +40 241 545 650
Fax: +40 241 555 582

RUSSIA

Moretron Service Ltd.
SIVA Center
Podgornaya Str. Rybny Port
183001 Murmansk
Tel.: +7 8152 459781
Fax: +7 8152 459791
www.moretron.ru

Simbia Engineering Company, Ltd.
4A Verhneozernaya Str.
236018 Kaliningrad
Tel.: +7 0112 215492
Fax: +7 0112 365380

Norwegian Partners
Marine AS
5-A Svetlanskaya Str.
690091 Vladivostok
Tel.: +7 4232 414627
Fax: +7 4232 300457
www.npm.no

SPAIN

Simrad Spain, S.L.
Partida Torres N° 38
Nave 8 Y 9
E-03570 Villajoyosa
(Alicante)
Tel.: +34 96 681 01 49
Fax: +34 96 685 23 04
www.simrad.sl

SWEDEN

Simrad AB
Svalörtsgratan 14
42668 Västra Frölunda
Tel.: +46 31 69 51 00
Fax: +46 31 69 51 20
www.simrad.se

SWITZERLAND

Marine Parts Heimgartner
Pfäffikerstr. 6
CH-8604 Volketswil/Zürich
Tel.: +41 1 997 40 90
Fax: +41 1 997 40 94

TURKEY

Promar Marine Equip. Ltd.
Igrip Sokak Gul Apt. No: 7/2
81030 Fenerbahe
Istanbul
Tel.: +90 216 3460894
Fax: +90 216 3461493
www.promar.com.tr

AFRICA

MOROCCO

Soremar
17 Rue le Catelet
BD Emile Zola
21900 Casablanca
Tel.: +212 22 40 50 50
Fax: +212 22 24 82 36

NORTH WEST AFRICA

Simrad NW Africa
1, Place Al Istiqlal
Angle Ave. Des FAR
20000 Casablanca
Morocco
Tel.: +212 22 54 1816/1535
Fax: +212 22 54 15 37

SOUTH AFRICA

Marine Radio Acoustic
Devices
P. O. Box 12076
N1 City 7463
Cape Town
Tel.: +27 21 559 4003
Fax: +27 21 559 2752

MIDDLE EAST

ISRAEL

YAMIT Y.S.B LTD.
P. O. Box 6158
61061 Tel-Aviv
Tel.: +972 3 5271 778
Fax: +972 3 5271 772

UNITED ARAB EMIRATES

Emphor FZCO
P. O. Box 61232
Dubai
Tel.: +97 148 830 233
Fax: +97 148 830 133

LEBANON

Selcom Marine Sarl
P. O. Box 55541
Dekwaneh Main Street
Beirut
Tel.: +961 149 1489
Fax: +961 149 5325

IRAN

Darya Negar Co.
Office 2, 1st Floor,
Bldg. No. 64
Fatemi Square
Teheran
Tel.: +98 21 896 7872
Fax: +98 21 896 6658

PACIFIC

AUSTRALIA

Quin Marine Pty. Ltd.
89 St Vincent Street
Port Adelaide, SA 5015
Tel.: +61 88 447 1277
Fax: +61 88 341 0567

NEW ZEALAND

Advance Trident Ltd.
P.O. Box 4174
Kingsland
Auckland
Tel.: +64 9 845 5347
Fax: +64 9 845 5348
www.advancetrident.com

ASIA

SINGAPORE

Jason Electronics Pte Ltd.
Blk 194 Pandan Loop #06-05
Pantech Industrial Complex
Singapore 128383
Tel.: +65 6 872 0211
Fax: +65 6 872 1800
www.jason.com.sg

CHINA & HONG KONG

CITE Limited
Rm C-E, 16/F, Yan's Tower,
26-27 Wong Chuk Hang Road
, Aberdeen
Tel.: +852 2 552 0178
Fax: +852 2 873 0679

INDIA

Norinco Pvt Ltd.
Karshaka Road
Cochin 682016
Tel.: +91 484 2323 675
Fax: +91 484 2323 694
www.norinco.co.in

INDONESIA

PT Sarana Teknologi
Wisma Dharmala Sakti
Annexe Building 7th Floor
JL. Jenderal Sudiram Kav.32
Jakarta 10220
Tel.: +62 21 570 61 28
Fax: +62 21 570 72 21
www.oceantechservices.com

SOUTH KOREA

Lucky Susan Co. Ltd.
K.P.O. Box 1666, Seoul
Taesung B/D. #508
60-17, Taepyong-Ro 1-Ka
Chung-Ku, Seoul
Tel.: +82 2 736 4328
Fax: +82 2 739 5689

Turn-On Electronics Co.
7th fl., Dong-A Ilbo Bldg.
53-11, 4-KA,
Choongang-Dong
Choong-Ku, Pusan
Tel.: +82 51 462 3930
Fax: +82 51 462 3089

JAPAN

Nippon Kaiyo Co. Ltd.
9-2 Sakae-Cho
Kita-Ku
Tokyo 114-0005
Tel.: +81 3 3913 2337
Fax: +81 3 3913 3479

Shipmate Japan Co. Ltd.
2-5-4 Fukuura
Kanazawa-ku
Yokohama 236-0004
Tel.: +81 45 788 2731
Fax: +81 45 788 2732

TAIWAN

Dragon & Elephant Enterprise
Co. Ltd.
12F-4, No. 251
Min Chuan 1st Road
Kaohsiung, Taiwan ROC
Tel.: +886 722 72887
Fax: +886 722 72910
Dragon43@ms8.hinet.net

PHILIPPINES

Norwegian Marine
Consultancy, Inc.
Building 1, Cebu Yatch Club,
Pusok, Lapu-Lapu City 6015
Tel.: +63 32 34 00 292
Fax: +63 32 34 01 194

AMERICAS

CANADA

Simrad Canada Ltd.
P.O. Box 397
112 Lincoln Street
Lunenburg, Nova Scotia
Canada B0J 2C0
Tel.: +1 902 640 3300
Fax: +1 902 640 3070
www.simrad.com

USA

Simrad Inc.
19210 33rd Avenue West
Suite A
Lynnwood WA 98036
Tel.: +1 425 778 8821
Fax: +1 425 771 7211
www.simrad.com

ARGENTINA

R.C. International
Av. Corrientes 2958 11th 38
1193 Buenos Aires
Tel.: +54 11 4862 5774/4865
7621
Fax: +54 11 4862 5774

BRAZIL

Electra Service
Av. Eugenio Fisher, 300
Jd. Guaiuba, Pier 26
Guarujá - Sao Paulo /SP
CEP 11401-970
Tel.: +55 13 3354 3599
Fax: +55 13 3354 3471
www.electraservice.com.br

CHILE

Simrad S.A.
Casilla 19012, Correo 19
Vitacura
Santiago
Tel.: +56 2 207 3059
Fax: +56 2 207 2695

PERU

Simrad Peru S.A.
Calle Los Topacios 266-268
Urb. San Antonio
Bellavista - Callao
Tel.: +51 1 453 7477
Fax: +51 1 453 7325

The above companies represent only main importers. Each country is in addition served by a network of local service outlets.

Some importers represent only specific market segments according to the following codes:

Professional:
Coastal and Fishery market
Recreational:
Leisure market

SIMRAD
A KONGSBERG Company